

# Stainless and High Alloy Steel Valves

JIS 5K/10K/20K, ASME Class 150/300/600/900/1500,  
Gate, Globe and Check Valves





# CONTENTS

■ Standard Product Range of KITZ Stainless and High Alloy Steel Valves	02	■ <b>SERIES HA</b>	Gate	39
■ Corrosion Resistant Service with KITZ Stainless and High Alloy Steel Valves	06	■ <b>SERIES C</b>	Gate	41
■ Features of Austenitic Stainless Steel as Valve Material	07		Globe	46
■ Material Reference Chart	08		Swing check	51
■ General Design Specifications	10	■ <b>SERIES B</b>	Gate	56
■ Bonnet Gasket Materials	10		Globe	57
■ Gland Packing Materials	10		Swing check	60
■ General Design Specifications	10		Lift check	61
■ Chromite Sand Molds for Stainless Steel Valve Castings	11		Strainer	62
■ KITZ Low Emission Service Valves	12	■ <b>SERIES D</b>	Gate	63
■ Inspection and Warranty Policy of KITZ Corporation	13		Globe	64
■ KITZ Low Temperature and Cryogenic Service Valves	13		Swing check	65
■ <b>SERIES A</b>		■ <b>SERIES AJ</b>	Gate	66
Gate	14		Globe	67
Globe	19		Swing check	74
Soft seated globe	23		Lift check	78
Bellows seat globe	25	■ Pressure-Temperature Ratings <For reference> Standard Class Valves, Flanged and Butt Weld End.		82
Swing check	29	■ Pressure-Temperature Ratings for Series B (KITZ Standard)		82
Lift check	34	■ Valve Closure Test Pressures		82
Strainer	38	■ Care for Handling Valves		82

PROVIDED BY: PT. SINAR MAS SAKTI  
 TEL: (62 21) 6008088 FAX: (62 21) 6293410 EMAIL: sales@smsakti.com

Standard Product Range of KITZ Stainless and High Alloy Steel Valves (Series A and C)

Series	Valve type	Nominal pressure	Design Standard		End connection	Shell material	Product code	
			P-T rating	Wall thickness				
A	Gate	Class 150	ASME B16.34	ASME B16.34	ASME 150 RF-flanged	CF8	150UMA	
						CF8M	150UMAM	
		Class 300			ASME 300 RF-flanged	CF8	300UMA	
						CF8M	300UMAM	
		Class 600			ASME 600 RF-flanged	CF8(CF8M)	600UMA(M)	
		10K			JIS B2220	ASME B16.34 Class 150	JIS 10K RF-flanged	SCS13A
	JIS 20K RF-flanged		SCS14A	10UMAM(T)				
	Globe	Class 150	ASME B16.34	ASME B16.34	ASME 150 RF-flanged	CF8	150UPA	
						CF8M	150UPAM	
		Class 300			ASME 300 RF-flanged	CF8	300UPA	
						CF8M	300UPAM	
		Class 600			ASME 600 RF-flanged	CF8(CF8M)	600UPA(M)	
		10K			JIS B2220	ASME B16.34 Class 150	JIS 10K RF-flanged	SCS13A
	JIS 20K RF-flanged		SCS14A	10UPAM(T)				
	20K	JIS B2220	ASME B16.34 Class 300	JIS 20K RF-flanged	SCS13A	20UPA		
				JIS 20K RF-flanged	SCS14A	20UPAM		
	Soft seated globe	10K	JIS B2220	ASME B16.34 Class 150	JIS 10K RF-flanged	SCS13A	10UPDA	
	Bellows Seal globe	Class 150	ASME B16.34	ASME B16.34	ASME 150 RF-flanged	CF8	150UPAW	
						CF8M	150UPAWM	
		Class 300			ASME 300 RF-flanged	CF8	300UPAW	
						CF8M	300UPAWM	
		10K	JIS B2220	ASME B16.34	ASME B16.34	JIS 10K RF-flanged	SCS13A	10UPAW
						JIS 20K RF-flanged	SCS14A	10UPAWM
		20K	JIS B2220	ASME B16.34	ASME B16.34	JIS 20K RF-flanged	SCS13A	20UPAW
						JIS 20K RF-flanged	SCS14A	20UPAWM
	Swing check	Class 150	ASME B16.34	ASME B16.34	ASME 150 RF-flanged	CF8	150UOA	
						CF8M	150UOAM	
		Class 300			ASME 300 RF-flanged	CF8	300UOA	
CF8M						300UOAM		
Class 600		ASME 600 RF-flanged			CF8(CF8M)	600UOA(M)		
10K		JIS B2220			ASME B16.34 Class 150	JIS 10K RF-flanged	SCS13A	10UOA(T)
	JIS 20K RF-flanged		SCS14A	10UOAM(T)				
20K	JIS B2220	ASME B16.34 Class 300	JIS 20K RF-flanged	SCS13A	20UOA			
			JIS 20K RF-flanged	SCS14A	20UOAM			
Lift check	Class 150	ASME B16.34	ASME B16.34	ASME 150 RF-flanged	CF8	150UNAM		
					CF8M	150UNAM		
	Class 300			ASME 300 RF-flanged	CF8	300UNA		
					CF8M	300UNAM		
	10K			JIS B2220	ASME B16.34 Class 150	JIS 10K RF-flanged	SCS13A	10UNA(T)
						JIS 20K RF-flanged	SCS14A	10UNAM(T)
20K	JIS B2220	ASME B16.34 Class 300	JIS 20K RF-flanged	SCS13A	20UNA			
			JIS 20K RF-flanged	SCS14A	20UNAM			
Strainer	10K	JIS B2220	ASME B16.34 Class 150	JIS 10K RF-flanged	SCS13A	10UYA		
HA	Gate	Class 150	ASME B16.34	API 603	ASME 150 RF-flanged	CF8M	150UMHAM	
					ASME 300 RF-flanged	CF8M	300UMHAM	
C	Gate	Class 150	ASME B16.34	API 600	ASME 150 RF-flanged	CF8(CF8M)	150UMC(M)	
							ASME 300 RF-flanged	300UMC(M)
		Class 300			ASME 300 RF-flanged		600UMC(M)	
							ASME 600 RF-flanged	900UMC(M)
		Class 600			ASME 600 RF-flanged		1500UMC(M)	
							ASME 900 RF-flanged	1500UMC(M)
	Globe	Class 150	ASME B16.34	API 600	ASME 150 RF-flanged	CF8(CF8M)	150UPC(M)	
							ASME 300 RF-flanged	300UPC(M)
		Class 300			ASME 300 RF-flanged		600UPC(M)	
							ASME 600 RF-flanged	900UPC(M)
		Class 600			ASME 600 RF-flanged		1500UPC(M)	
							ASME 900 RF-flanged	1500UPC(M)
	Swing check	Class 150	ASME B16.34	API 600	ASME 150 RF-flanged	CF8(CF8M)	150UOC(M)	
							ASME 300 RF-flanged	300UOC(M)
		Class 300			ASME 300 RF-flanged		600UOC(M)	
							ASME 600 RF-flanged	900UOC(M)
		Class 600			ASME 600 RF-flanged		1500UOC(M)	
							ASME 900 RF-flanged	1500UOC(M)
Class 900	ASME 900 RF-flanged	ASME 1500 RF-flanged	1500UOC(M)					
		ASME 1500 RF-flanged	1500UOC(M)					

\* Product codes suffixed (T) stands for the valves provided with ceramic filled PTFE gaskets and PTFE packings

Nominal size	A B	1/2	3/4	1	1 1/4	1 1/2	2	2 1/2	3	4	5	6	8	10	12	14	16	18	20	24	page	
		15	20	25	32	40	50	65	80	100	125	150	200	250	300	350	400	450	500	600		
		●	●	●		●	●	●	●	●	●	●	●	●	●	●	●	●	●	●	14	
		●	●	●		●	●	●	●	●	●	●	●	●	●	●	●	●	●	●	●	14
																					14	
		●	●	●		●	●	●	●	●	●	●	●	●	●	●	●	●	●	●	●	15
		●	●	●		●	●	●	●	●	●	●	●	●	●	●	●	●	●	●	●	15
		●	●	●		●	●	●	●	●	●	●	●	●	●	●	●	●	●	●	●	16
		●	●	●	●	●	●	●	●	●	●	●	●	●	●	●	●	●	●	●	●	17
		●	●	●	●	●	●	●	●	●	●	●	●	●	●	●	●	●	●	●	●	17
		●	●	●		●	●	●	●	●	●	●	●	●	●	●	●	●	●	●	●	18
		●	●	●		●	●	●	●	●	●	●	●	●	●	●	●	●	●	●	●	18
		●	●	●		●	●	●	●	●	●	●	●	●	●	●	●	●	●	●	●	19
		●	●	●		●	●	●	●	●	●	●	●	●	●	●	●	●	●	●	●	19
		●	●	●		●	●	●	●	●	●	●	●	●	●	●	●	●	●	●	●	20
		●	●	●		●	●	●	●	●	●	●	●	●	●	●	●	●	●	●	●	20
		●	●	●		●	●	●	●	●	●	●	●	●	●	●	●	●	●	●	●	21
		●	●	●	●	●	●	●	●	●	●	●	●	●	●	●	●	●	●	●	●	22
		●	●	●	●	●	●	●	●	●	●	●	●	●	●	●	●	●	●	●	●	22
		●	●	●		●	●	●	●	●	●	●	●	●	●	●	●	●	●	●	●	23
		●	●	●		●	●	●	●	●	●	●	●	●	●	●	●	●	●	●	●	23
		●	●	●	●	●	●	●	●	●	●	●	●	●	●	●	●	●	●	●	●	24
		●	●	●	●	●	●	●	●	●	●	●	●	●	●	●	●	●	●	●	●	24
		●	●	●		●	●	●	●	●	●	●	●	●	●	●	●	●	●	●	●	25
		●	●	●		●	●	●	●	●	●	●	●	●	●	●	●	●	●	●	●	25
		●	●	●		●	●	●	●	●	●	●	●	●	●	●	●	●	●	●	●	26
		●	●	●		●	●	●	●	●	●	●	●	●	●	●	●	●	●	●	●	26
		●	●	●		●	●	●	●	●	●	●	●	●	●	●	●	●	●	●	●	27
		●	●	●		●	●	●	●	●	●	●	●	●	●	●	●	●	●	●	●	27
		●	●	●		●	●	●	●	●	●	●	●	●	●	●	●	●	●	●	●	28
		●	●	●		●	●	●	●	●	●	●	●	●	●	●	●	●	●	●	●	28
																					29	
																						29
																						30
																						30
																						31
																						32
																						32
																						33
																						33
		●	●	●		●	●	●	●	●	●	●	●	●	●	●	●	●	●	●	●	34
		●	●	●		●	●	●	●	●	●	●	●	●	●	●	●	●	●	●	●	34
		●	●	●		●	●	●	●	●	●	●	●	●	●	●	●	●	●	●	●	35
		●	●	●		●	●	●	●	●	●	●	●	●	●	●	●	●	●	●	●	36
		●	●	●	●	●	●	●	●	●	●	●	●	●	●	●	●	●	●	●	●	37
		●	●	●	●	●	●	●	●	●	●	●	●	●	●	●	●	●	●	●	●	37
		●	●	●		●	●	●	●	●	●	●	●	●	●	●	●	●	●	●	●	38
		●	●	●		●	●	●	●	●	●	●	●	●	●	●	●	●	●	●	●	38
																						39
																						39
		●	●	●		●	●	●	●	●	●	●	●	●	●	●	●	●	●	●	●	40
		●	●	●		●	●	●	●	●	●	●	●	●	●	●	●	●	●	●	●	40
		●	●	●		●	●	●	●	●	●	●	●	●	●	●	●	●	●	●	●	41
		●	●	●		●	●	●	●	●	●	●	●	●	●	●	●	●	●	●	●	42
		●	●	●		●	●	●	●	●	●	●	●	●	●	●	●	●	●	●	●	43
																						44
																						45
		●	●	●		●	●	●	●	●	●	●	●	●	●	●	●	●	●	●	●	46
		●	●	●		●	●	●	●	●	●	●	●	●	●	●	●	●	●	●	●	47
		●	●	●		●	●	●	●	●	●	●	●	●	●	●	●	●	●	●	●	48
																						49
																						50
		●	●	●		●	●	●	●	●	●	●	●	●	●	●	●	●	●	●	●	51
		●	●	●		●	●	●	●	●	●	●	●	●	●	●	●	●	●	●	●	52
				●		●	●	●	●	●	●	●	●	●	●	●	●	●	●	●	●	53
																						54
							●	●	●	●	●	●	●	●	●	●	●	●	●	●	●	55

PROVIDED BY: PT SINAR MAS SAKTI  
 TEL: (62 21) 6008088 FAX: 16222116223410 EMAIL: sales@smsakti.com

Standard Product Range of KITZ Stainless and High Alloy Steel Valves (Series B, D and AJ)

Series	Valve type	Nominal pressure	Design Standard		End connection	Shell material		
			P-T rating	Wall thickness				
B	Gate	10K	KITZ Std.	KITZ Std.	Threaded	SCS13A		
						SCS14A		
		Flanged			SCS13A			
					SCS14A			
	Type 200	CF8M						
	Globe	5K	KITZ Std.	KITZ Std.	Flanged	SCS13A		
						SCS14A		
		10K			Threaded	SCS13A		
						SCS14A		
	Type 200	Flanged	SCS13A					
			SCS14A					
	Soft seated globe	10K	KITZ Std.	KITZ Std.	Threaded	SCS13A		
						SCS14A		
	Flanged	SCS13A						
SCS14A								
Swing check	10K	KITZ Std.	KITZ Std.	Threaded	SCS13A			
					SCS14A			
	Flanged			SCS13A				
				SCS14A				
Type 200	CF8M							
Lift check	10K	Threaded	SCS13A					
Strainer	10K	KITZ Std.	KITZ Std.	Flanged	SCS13A			
					SCS14A			
	20K			Threaded	SCS13A			
					SCS14A			
D	Gate	Class 150	ASME B16.34	ASME B16.34	AK:Threaded AW:Socket Welded	CF8M (CF8M)		
		Class 300						
		Class 600						
	Globe	Class 150						
		Class 300						
		Class 600						
Swing check	Class 150							
	Class 300							
	Class 600							
AJ	Gate	Class 150	ASME B16.34	ASME B16.34	ASME B16.34 RF-flanged	CF8 (CF8M)		
		Class 300						
		10K				ASME B16.34 Class 150	JIS 10K RF-flanged	SCS13A
		20K				ASME B16.34 Class 300	JIS 20K RF-flanged	(SCS14A)
	Globe	Class 150	ASME B16.34	ASME B16.34	ASME B16.34 RF-flanged	CF8 (CF8M)		
		Class 300						
		10K				ASME B16.34 Class 150	JIS 10K RF-flanged	SCS13A
		20K				ASME B16.34 Class 300	JIS 20K RF-flanged	(SCS14A)
	Swing check	Class 150	ASME B16.34	ASME B16.34	ASME B16.34 Class 150 RF-flanged ASME B16.34 Class 300 RF-flanged	CF8 (CF8M)		
		Class 300						
		10K				ASME B16.34 Class 150	JIS 10K RF-flanged	SCS13A
		20K				ASME B16.34 Class 300	JIS 20K RF-flanged	(SCS14A)
Lift check	Class 150	ASME B16.34	ASME B16.34	ASME B16.34 Class 150 RF-flanged ASME B16.34 Class 300 RF-flanged	CF8 (CF8M)			
	Class 300							
	10K				ASME B16.34 Class 150	JIS 10K RF-flanged	SCS13A	
	20K				ASME B16.34 Class 300	JIS 20K RF-flanged	(SCS14A)	

\* Product codes suffixed (T) stands for the valves provided with ceramic filled PTFE gaskets and PTFE packings

Product Coding (Except for Series B)

**AK-150 U M A M 4**

1 2 3 4 5 6 7

1 End connection

None: RF-flanged with smooth finished gasket face

AK : Threaded ends to ASME B1.20.1 NPT

AW : Socket welding ends to ASME B16.11

2 Nominal Pressure

Code	Nominal Pressure	Code	Nominal Pressure
5	JIS 5K	300	ASME 300
10	JIS 10K	600	ASME 600
20	JIS 20K	900	ASME 900
150	ASME Class150	1500	ASME Class1500

Nominal size	A	1/4	3/8	1/2	3/4	1	1 1/4	1 1/2	2	2 1/2	3	4	5	6	page
UEL				●	●	●	●	●	●						56
UELM				●	●	●	●	●	●						56
UE										●	●	●			56
UEM										●	●	●			56
UEB				●	●	●	●	●	●	●	●	●			56
UEBM						●	●	●	●	●	●	●			56
AKUELM															57
AKUEM															57
UAB			●	●	●	●	●	●	●						57
UCL	●		●	●	●	●	●	●	●						58
UJ			●	●	●	●	●	●	●	●	●	●			58
UJM			●	●	●	●	●	●	●	●	●	●			58
UCB			●	●	●	●	●	●	●	●	●	●			58
UJB			●	●	●	●	●	●	●	●	●	●			59
UJBM			●	●	●	●	●	●	●	●	●	●			59
AKUCLM															59
AKUJM															59
UD			●	●	●	●	●	●	●						60
UDM			●	●	●	●	●	●	●						60
UDB				●	●	●	●	●	●	●	●	●			60
UDBM				●	●	●	●	●	●	●	●	●			60
UO				●	●	●	●	●	●	●	●	●			60
UOM				●	●	●	●	●	●	●	●	●			60
UOB				●	●	●	●	●	●	●	●	●			61
UOBM				●	●	●	●	●	●	●	●	●			61
AKUOM															61
UN			●	●	●	●	●	●	●						61
UYB			●	●	●	●	●	●	●						62
UYBM			●	●	●	●	●	●	●						62
UY	●		●	●	●	●	●	●	●	●	●	●			62
UYM	●		●	●	●	●	●	●	●	●	●	●			62
AK/AW 150UMM(O)				●	●	●	●	●	●			●			62
AK/AW 300UMM(O)				●	●	●	●	●	●			●			63
AK/AW 600UMM(O)				●	●	●	●	●	●			●			63
AK/AW 150UPM(O)				●	●	●	●	●	●			●			63
AK/AW 300UPM(O)				●	●	●	●	●	●			●			64
AK/AW 150UOM(O)				●	●	●	●	●	●			●			64
AK/AW 300UOM(O)				●	●	●	●	●	●			●			64
150UMAJ(M)				●	●	●	●	●	●			●		●	66
300UMAJ(M)				●	●	●	●	●	●			●		●	67
10UMAJ(M)				●	●	●	●	●	●			●		●	68
20UMAJ(M)				●	●	●	●	●	●			●		●	69
150UPAJ(M)				●	●	●	●	●	●			●		●	70
300UPAJ(M)				●	●	●	●	●	●			●		●	71
10UPAJ(M)				●	●	●	●	●	●			●		●	72
20UPAJ(M)				●	●	●	●	●	●			●		●	73
150UOAJ(M)									●			●		●	74
300UOAJ(M)									●			●		●	75
10UOAJ(M)									●			●		●	76
20UOAJ(M)									●			●		●	77
150UNAJ(M)				●	●	●	●	●	●						78
300UNAJ(M)				●	●	●	●	●	●						79
10UNAJ(M)				●	●	●	●	●	●						80
20UNAJ(M)				●	●	●	●	●	●						81

**3 Product identification**

U: Identification code for stainless and high alloy steel valves in general.

**4 Valve type**

M : Gate valves  
 P : Globe valves  
 PD : Soft seated globe valves  
 O : Swing check valves  
 N : Lift check valves  
 Y : Y-pattern strainers

**5 Valve design**

Code: Series  
 A : Series A  
 HA : Series HA  
 C : Series C  
 None: Series D  
 AJ : Series A, jacketed  
 AW : Series A, Bellows seal

**6 Shell material**

None: CF8 (304)  
 M : CF8M (316)  
 O : CF3M (316L)  
 V : CF3 (304L)  
 CB : CF8C (321)  
 CG : CG8M (317)  
 CK : CK20 (310)  
 SD : SCS10 (SDPV-K1)  
 CN : CN7M (Alloy 20)  
 HB : N-12MV (Hastelloy B)  
 HC : CW-12MW (Hastelloy C)

**7 Nominal valve size**

JIS flanged : in mm base  
 Others : in inches base

**Corrosion Resistant Service with KITZ Stainless and High Alloy Steel Valves**

KITZ stainless and high alloy steel valves widely utilized in chemical, petrochemical, food and beverage, pulp and paper, pharmaceutical and other industrial processing plants throughout the world, constitute one of the major product lines of KITZ Corporation, Japan, s largest manufacturer of industrial valves.

KITZ stainless and high alloy steel valves are designed, manufactured, and inspected to strictly conform with the requirements of ASTM, ASME, API, BS JIS and other internationally recognized standards, with all quality elements meeting the critical service conditions needed for corrosive industrial applications.

KITZ stainless and high alloy steel valves are characterized by unsurpassed corrosion resistant service and reliability, providing users with the lowest cost of ownership and the longest total life cycle performance in the industry. As an ISO 9001 certified valve manufacturer, KITZ Corporation has achieved a high degree of product standardization by the ideal combination of its updated technical know-how and uniquely integrated system of production adopted at its Nagasaka Plant, Yamanashi, Japan, the home of KITZ stainless and high alloy steel valves.

Electronically controlled steel foundries, multi-station transfer machining systems and state-of-the-art test and inspection facilities, are all put together at KITZ Nagasaka Plant, to ensure the quality and reliability of all products that it releases to the global market.



KITZ Nagasaka Plant, Japan



KITZ Corporation of Taiwan



KITZ Corporation of Kunshan

## Features of Austenitic Stainless Steel as Valve Material

Stainless steel is divided into three main categories depending on its chemical composition. They are martensitic stainless steel containing 13% chromium, ferritic stainless steel containing 18% chromium, and austenitic stainless steel containing 18% chromium and 8% nickel. Among them, austenitic stainless steel is widely used for both valve shells and trims, which require good pressure resistant characteristic. Martensitic stainless steel is used mainly for trims of carbon steel valves. The features and characteristics of these stainless steels are compared below:

### Features Of Stainless Steel by Types

Types	Martensitic	Ferritic	Austenitic
Typical material	AISI 410	AISI 430	ASTM CF8M / F316
Magnetization	Yes		No
Hardening by heat treatment	Yes	No	
Hardening by machining	Same as soft steel		Less
Corrosion and acid resistance	Good		Excellent
Impact resistance and elongation	Good		Excellent
Weldability	Poor	Fair	Good
Lowest service temperature	-29°C	-10°C	-269°C

As shown below, austenitic stainless steel has an excellent impact value in subzero temperature range and been almost exclusively used for cryogenic service applications. It also features higher heat resistance than carbon steel. Its tensile strength is also superior to other valve materials and its high resistance against destructive tensile load in a wide range of service temperature is unrivaled by other valve material. Corrosive fluid cannot generally affect these excellent mechanical properties of austenitic stainless steel.

### Compared Impact Values

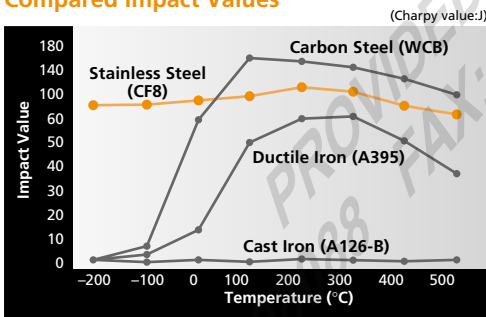

### Steel Castings : Maximum Working Temperature Range

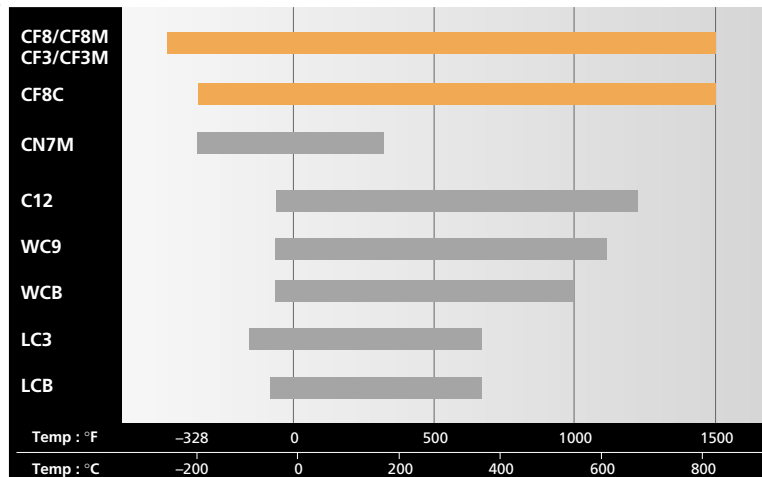

### Compared Tensile Strength

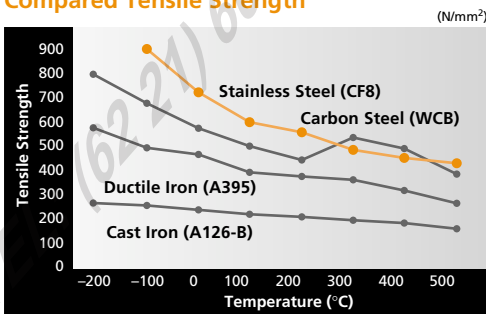

This data reflects ASTM specifications for general steel castings, and does not necessarily apply to valves made of these materials, which are subject to highly demanding service conditions as pressure containing vessels.

On the other hand, austenitic stainless steel is known as a very mild metal having no effect on the quality of the materials it comes into contact with. Line fluid is not contaminated while travelling through austenitic stainless steel pipelines. This advantage makes austenitic stainless steel valves the important fluid handling media for food, beverage and pharmaceutical processing plants. In addition, austenitic stainless steel CF8M or F316 has higher resistance to sea water erosion and is widely used for the valves installed in seawater desalination plants, offshore exploration facilities and ocean structures.

Material Reference Chart

Classification	KITZ Codes	Main Ingredients	Shell Material Code	Standards				Standards		
				Castings				Bar or Forgings		
				ASTM	DIN (W.-Nr.)	UNS-No.	JIS	ASTM	DIN (W.-Nr.)	
Iron based alloy	<b>Martensitic Stainless Steel</b>									
	CA6NM	13Cr-4Ni-0.8Mo		A743 CA6NM	1.4313	J91540	SCS6	A276 S41500	1.4313	
	<b>Austenitic Stainless Steel</b>									
	SCS13	18Cr-8Ni		A351 CF8	1.4308	J92600	SCS13A	A276 304	1.4301	
	KA13	18Cr-8Ni-LS (1)								
	SCS19	18Cr-8Ni-LC (2)	V	A351 CF3	1.4306	J92500	SCS19A	A276 304L	1.4306	
	SCS14	18Cr-9Ni-2Mo	M	A351 CF8M	1.4408	J92900	SCS14A	A276 316	1.4401	
	KA14	18Cr-9Ni-2Mo-LS (1)	M							
	SCS16	18Cr-9Ni-2Mo-LC (2)	O	A351 CF3M	1.4404	J92800	SCS16A	A276 316L	1.4404	
	SCS21	18Cr-10Ni-Nb	CB	A351 CF8C	1.4552	J92710	SCS21	A276 347	1.4550	
	CG8M	18Cr-12Ni-3.5Mo	CG	A351 CG8M	—	J93000	—	A276 317	1.4449	
	CG3M	18Cr-12Ni-3.5Mo-LC (2)	CG	A351 CG3M	—	J92999	—	A276 317L	1.4438	
	KSN1	18Cr-13Ni-4.5Si	SN	—	—	—	—	—	—	
	CN7M	21Cr-29Ni-2.5Mo-3.5Cu	CN	A351 CN7M	1.4536	J95150	SCS23	A437 N08020	2.4660	
	CN3MCu	21Cr-29Ni-2.7Mo-3.2Cu-LC (2)	(-)*	A990 CN3MCu	—	—		—	—	—
	CK20	25Cr-20Ni	CK	A351 CK20	—	J94202	SCS18	A276 310S	1.4845	
	K800	33Ni-20Cr-45Fe-Nb	CT	A351 CT15C	1.4859	N28820	—	B408 N08800	1.4876	
	<b>Super Austenitic Stainless Steel</b>									
	SASV-Z1	21Cr-24Ni-6.5Mo-N	SA	A351 CN3MN	—	—	—	B691 N08367	—	
	SASV-Z2	25Cr-24Ni-6.5Mo-N	SA	A351 CN3MN mod.	—	—	—	—	—	
	SASV-Z3	20Cr-18Ni-6.5Mo-N-Cu	SA	A351 CK3MCuN	—	J93254	—	A276 S31254	—	
	<b>Duplex Stainless Steel</b>									
	KDPV22	22Cr-5Ni-3Mo-N	4A	A890 Gr.4A CD3MN	—	J92205	—	A276 S32205	1.4462	
	<b>Super Duplex Stainless Steel</b>									
	SDPV-K1	25Cr-7Ni-3Mo-N	SD	—	—	—	SCS10	A479 S32750	1.4460	
	SDPV-K2	28Cr-7Ni-4Mo-N	SD	—	—	—	SCS10 mod.	—	—	
SDPV-K3	25Cr-7Ni-3Mo-Cu-N-W	SD	A890 Gr.6A CD3MWCuN	1.4468	J93380	—	A479 S32750	1.4460		
<b>Ni-Cu Alloy</b>										
M-35-1	67Ni-30Cu	NC	A494 M-35-1	2.4365	N24135	NCuC	B164 N04400	2.4360		
<b>Ni-Cr Alloy</b>										
K600	78Ni-15Cr-5Fe	CY	A494 CY-40	2.4816	N06040	NCrFC	B166 N06600	2.4817		
<b>Ni-Mo Alloy</b>										
HB-K1	67Ni-28Mo-5Fe	HB	A494 N-12MV	2.4882	N30012	NMC	B335 N10001	2.4819		
HB-K2	68Ni-31Mo-1Fe	HB	A494 N-7M	2.4617	N30007	—	B335 N10665	2.4856		
<b>Ni-Cr-Mo Alloy</b>										
HC-K1	58Ni-16Cr-16Mo-6Fe-4W	HC	A494 CW-12MW	2.4686	N30002	NMCrC	B574 N10276	2.4819		
HC-K2	58Ni-21Cr-14Mo-4Fe-3W	HC	A494 CX2MW	9.4602	N26022	—	B574 N06022	2.4602		
K625	65Ni-22Cr-9Mo-3.5Nb	CW	A494 CW-6MC	2.4856	N26625	—	B446 N06625	2.4856		
K825	43Ni-22Cr-3Mo-30Fe-Nb	CU	A494 CU5MCuC	2.4858	N08826	—	B425 N08825	2.4858		
<b>Nickel</b>										
CZ-100	97Ni	CZ	A494 CZ-100	—	N02100	—	B160 N02200	2.4068		

※ (1) S < 0.002 mass%  
 ※ (2) C < 0.03 mass%

		Characteristics	Typical application	Equivalent
UNS-No.	JIS			
S41500	—	Higher corrosion resistance and weldability than other martensitic stainless steel with Ni and Mo	Oil well and oil refining	—
S30400	SUS 304	Superior corrosion resistance to nitric acid, phosphoric acid and organic acid Improved 304 with higher pitting and crevice corrosion resistance	Pulp and paper mills, chemical processes, and seawater service	—
S30403	SUS 304L	Higher intergranular corrosion resistance than CF8		—
S31600	SUS 316	Higher pitting corrosion resistance than CF8 Improved 316 with higher pitting and crevice corrosion resistance		—
S31603	SUS 316L	Higher intergranular corrosion resistance than CF8M		—
S34700	SUS 347	Higher intergranular corrosion resistance than CF8 with carbide stabilized with Nb		—
S31700	SUS 317	Higher pitting and crevice corrosion resistance than CF8M		Power generation, seawater service, and oil pipelines
S31703	SUS 317L	Higher pitting and crevice corrosion resistance than CF8M	Power generation, seawater service, and oil pipelines	—
—	—	Superior corrosion resistance to nitric acid of any concentration and under fuming nitric acid environment	Nitric acid production processes	NAR-SN-1
N08020	—	Superior corrosion resistance to sulfuric acid of any concentration at 60°C and lower, and to heated dilute oxide	Chemical processes handling acetic acid, alkali, dilute hydrochloric acid, dilute hydrofluoric acid, dilute fluorosilic acid and phosphoric acid, also for oil refining	—
—	—	Superior corrosion resistance to sulfuric acid of any concentration at 60°C and lower, and to heated dilute oxide	Chemical processes handling acetic acid, alkali, dilute hydrochloric acid, dilute hydrofluoric acid, dilute fluorosilic acid and phosphoric acid, also for oil refining	—
S31008	SUS 310S	Used for sulfurous acid and dilute sulfuric acid at ambient temperature, with higher Cr and Ni contents than 304	Chemical processes	—
N08800	NCF800	Superior mechanical strength at high temperature and resistance to carburizing with stabilized structure to be used for long duration; also superior corrosion resistance under humid environment	Petrochemical and carburizing processes	Incoloy alloy 800
N08367	SUS 836L	The most superior acid and alkali resistance among all austenitic stainless steel and superior pitting and crevice corrosion resistance to chloride solution such as seawater	Chemical processes for highly concentrated chloride, flue gas desulfurization, acid and alkali reactor, salt manufacturing processes and seawater desalination	AL-6XN
—	—			—
S31254	—			254SMO
S32205	SUS 329J3L	The same corrosion resistance as CF3M; less expensive with lower Ni and Mo contents	Pulp and paper mills, chemical processes, and seawater service	SAF 2205
S32750	SUS 329J4L	Higher stress corrosion cracking resistance than austenitic stainless steel, higher weldability than ferritic stainless steel and higher acid, pitting and crevice corrosion resistance than CF3M with higher mechanical strength	Salt manufacturing processes, seawater desalination, and seawater service under chloride environment and dilute sulfuric acid, phosphoric acid, formic acid, acetic acid, and urea production under acid environment, also for chemical processes, flue gas desulfurization, and waste fluid concentration	—
—	—			—
S32750	—			DP3W, SAF 2507
N04400	—	Superior corrosion resistance under reducing environment, no local corrosion and stress corrosion cracking resistance	Chemical processes handling alkali chloride and boiled acid, also for oil refining	Monel alloy 400
N06600	NCF600	Superior corrosion resistance to pure water and alkali under oxidizing and high temperature environment; also resistant to stress corrosion cracking by Cl ions	Chemical and food processes	Inconel alloy 600
N10001	NM1B	Resistance to hydrochloric acid of any concentration up to boiling point, resistant to reducing chloride such as sulfuric acid (up to 60%), phosphoric acid and copper chloride, resistant to high temperature but not suitable under highly oxidizing environment	Corrosion resistant processes handling chlorine, sulfuric acid, phosphoric acid, acetic acid and hydrogen chloride gas, also for processes handling chloride with high concentration at high temperature	Hastelloy alloy B
N10665	NM2B			Hastelloy alloy B2
(N10276, N10002)	NMCrB	Superior resistance under oxidizing environment, such as wet chlorine gas and chlorine dioxide; also resistance to organic acid and chloride such as acetic acid and seawater	Processes handling oxidizing acid, formic acid, acetic anhydride and seawater, also for chemical processes handling fluoride	Hastelloy alloy C276
N06022	—			Hastelloy alloy C22
N06625	NCF625	Superior corrosion resistance under oxidizing and high temperature environment and superior erosion resistance	Chemical processes in general	Inconel alloy 625
N08825	NCF825	Superior corrosion resistance to sulfuric acid and phosphoric acid; also resistance to stress corrosion cracking and crevice corrosion	Chemical processes in general	Incoloy alloy 825
N02200	—			Alloy 200

Note: The above materials are applicable to valve shells. Contact KITZ Corporation for other valve component materials.  
SDPV and SASV are KITZ'S registered trademarks. (Other trademarks: SandvikAB for SAF 2205/SAF 2507, SPECIAL METALS for Inco/Monel, Haynes for Hastelloy)  
Allegheny Ludlum for AL-6XN, Avesta for 254SMO, SUMITOMO METALS for DP3W/NAR.

## General Design Specifications

Series	Normal pressure	Pressure - temperature ratings*	Face-to face dimensions	End connection dimensions	Wall thickness
A	10K	JIS B2220	JIS B2002	JIS B2220 10K flanged	ASME B16.34
	20K			JIS B2220 20K flanged	
HA	Class 150/300/600	ASME B16.34	ASME B16.10	ASME B16.5 flanged	API 603
C	Class 150/300/600/900/1500	ASME B16.34	ASME B16.10	ASME B16.5 flanged	API 600
B	5K	0.5MPa 150°C	JIS B 2011 KITZ Std.	JIS B0203 threaded	JIS B 2011 KITZ Std.
	10K	1.0MPa 180°C		JIS B2220 5K 10K flanged	
	20K	2.0MPa 180°C		ASME B1.20.1 threaded	
	Type 200	KITZ Std.			
D	Class 150/300/600	ASME B16.34	KITZ Std.	ASME B1.20.1 threaded ASME B16.11 socket welded	ASME B16.34
AJ	10K	JIS B2220	KITZ Std.	JIS B2220 10K flanged	ASME B16.34
	20K			JIS B2220 20K flanged	
	Class 150/300	ASME B16.34		ASME B16.5 flanged	

\*Actual pressure-temperature rating in service depends on the materials of gland packing and gasket chosen for valves.

## Bonnet Gasket Materials

Depending on class ratings and servicing conditions, following gasket materials are available\* for body/bonnet flange gaskets of KITZ stainless and high alloy steel valves. Specify your gasket material in your purchase order.

Series	Series C			Series A · HA · D · AJ		
	Class 150	Class 300	Class 600/900/1500	10K, Class 150	20k, Class 300	Class 600
Corrugated metal	●					
Ring joint metal			●			
Spiral wound metal, PTFE filled		●			●	●
Flexible graphite	●			●	●	
Spiral wound metal, flexible graphite filled		●			●	●
Stainless steel inserted flexible graphite	●			●	●	
Ceramic filled PTFE	●			●	●	

Note: Refer to Page 9 for bonnet gaskets used for KITZ low emission service valves. \*Except Series B valves which employ only KITZ standard materials.

## Gland Packing Materials



Following packing materials can be chosen for KITZ stainless and high alloy steel valves, depending on service conditions, or market requirements. Specify your packing material in your purchase order.

Asbestos-free	Packing material	Service conditions
	Braided PTFE fiber	260°C (500°F) corrosion resistant
PTFE cup & cone / PTFE V-ring	150°C (300°F) corrosion resistant	
Carbon fiber	500°C (930°F) high pressure	
Flexible graphite	600°C (1110°F)* corrosion resistant	
Inconel wired flexible graphite	600°C (1110°F)* corrosion resistant	

Note: Refer to Page 9 for gland packing sets used for KITZ low emission service valves. \*455°C(850°F) for oxidizing atmosphere.

Contact KITZ Corporation or your KITZ distributors for optional requirement of gasket or gland packing materials other than listed above.

## General Design Specifications

Series	Nominal Pressure	Solid wedge 	Flexible wedge 
A	10K, 20K, Class 150, 300, 600	—	All sizes
HA	Class 150, 300	—	All sizes
C	Class 150, 300	4 & smaller	6 & larger
	Class 600, 900, 1500	1 1/2 & smaller	2 & larger
B	5K, 10K, 20K, 200	All sizes	—
D	Class 150, 300, 600	—	All sizes
AJ	10K, 20K, Class 150, 300	—	All sizes

## Chromite Sand Molds for Stainless Steel Valve Castings

### Silica Sand

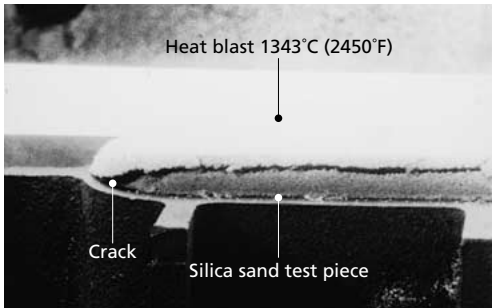

### Chromite Sand

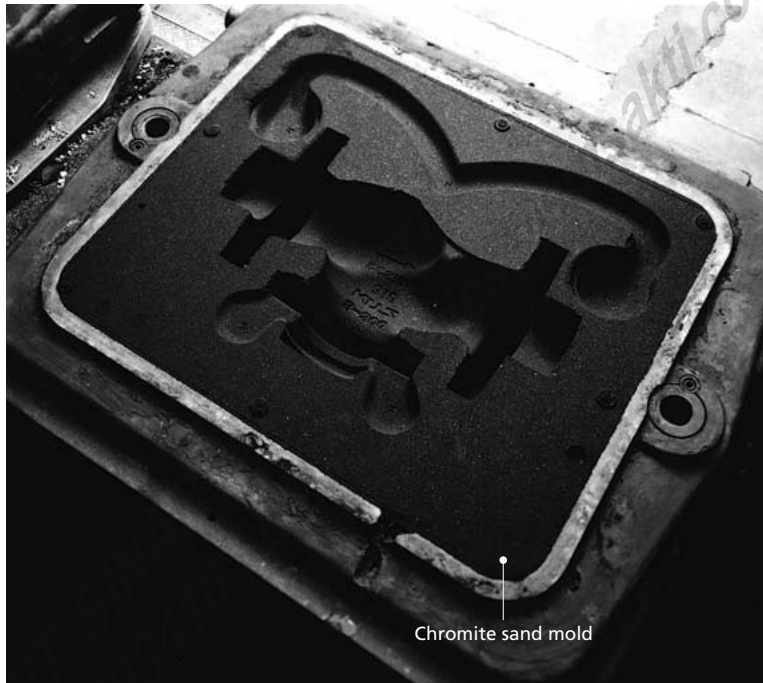
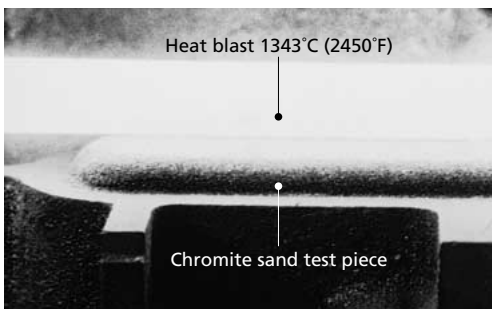

Unlike its competitors, KITZ Corporation employs casting molds made of 100% chromite sand at its Nagasaki stainless steel foundries, instead of the silica sand which is more popular in the industry. Its specific gravity is twice as much as that of silica sand, and loading 1.5MPa(210 psi) surface pressure during molding enables uncomparably solid, hard and uniform structure of casting molds with high precision. KITZ's sand treatment plants are designed for repetitive regeneration and recycling of used chromite sand, the most expensive casting mold material.

### Mold Sands: Cooling Effect

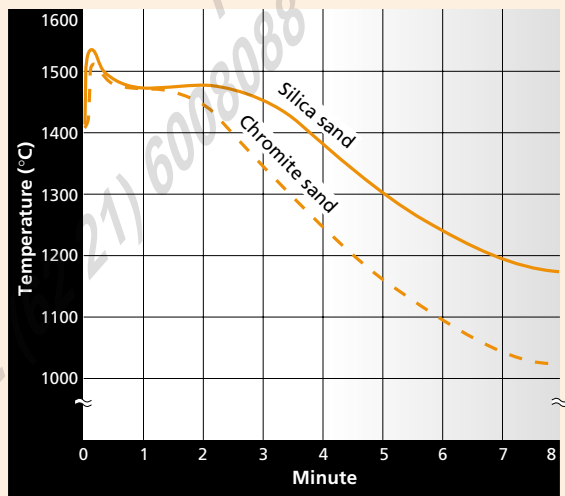

Much higher cooling effect of chromite sand solidifies the molten metal faster to result in very sound castings without concern of blowholes and other casting defects.

### Mold Sands: Decarbonization

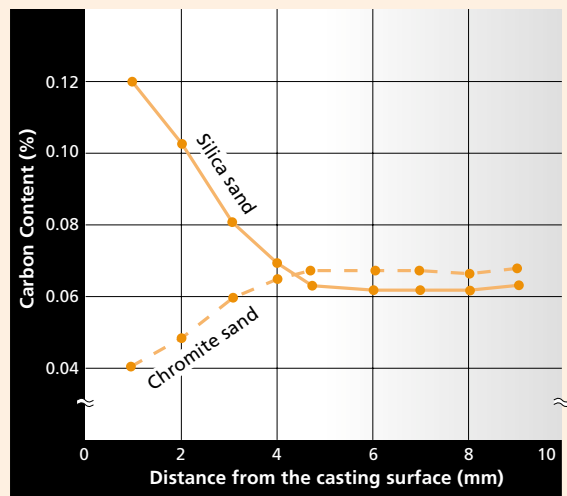

Chromite sand decarbonizes the surface area of stainless steel castings much better so that fine of casting surface and high corrosion resistance are guaranteed.

## KITZ Low Emission Service Valves

In the United States, the Federal Clean Air Act was dramatically amended in 1990, to realize the new environmental protection policy of a 95% reduction in fugitive emission or leak levels of toxic gases and chemicals from plant equipment. Promulgated in April, 1994, the new law requires all plants handling the toxic gas specified by the Environmental Protection Agency, to periodically monitor their plant equipment for detection of leaks exceeding 500 ppm, and repair or replace all defective parts immediately. California has exceeded the Federal law with a state regulation requiring 100 ppm maximum leak level for an astonishing 99% reduction of such an environmental pollution for the Northern California Region after 1997.

Our low emission valves, the proud fruits of several years of trial and error at our laboratory, are designed, engineered, manufactured and tested to now meet the 100 ppm maximum emission level. This is the standard specification in North America for KITZ Class 150, 300 and 600 Series A and C stainless and high alloy steel valves. In other markets, all these low emission valves are optionally available. Major design considerations for having upgraded our standard valves to the low emission performers are introduced below.

### Gland packing

Series A: Choice of PTFE or flexible graphite packing.

- (1) Braided PTFE fiber packing with spun carbon core
- (2) KITZ's original "SEALEVER®" packing set consisting of 4 dieformed flexible graphite rings\* and 2 braided flexible graphite wiper rings with a pure carbon spacer bush for Class 300 and 600.

Series HA:

- (1) Braided PTFE fiber packing with spun carbon core
- (2) KITZ's original "SEALEVER®" packing set consisting of 4 dieformed flexible graphite rings\* and 2 braided flexible graphite wiper rings with a pure carbon spacer bush for Class 300.

Series C: KITZ's original "SEALEVER®" graphite packing set with a pure carbon spacer bush for Class 300 and 600.

\*US Patent No. 5522603 & 5573253. Other patents registered or pending worldwide.

### Bonnet gaskets and check valve cover gaskets

Series A: Choice of PTFE or flexible graphite gasket.

- (1) Class 150 : Reinforced PTFE, Class 300 : PTFE filled spiral wound with inner ring. Class 600 : PTFE filled spiral wound
- (2) Class 150 : S/S inserted flexible graphite sheet designed with permeation protective barrier  
Class 300 : Spiral wound flexible graphite with inner ring. Class 600 : Spiral wound flexible graphite

Series HA: Choice of PTFE or flexible graphite gasket.

- (1) Class 150 : Reinforced PTFE, Class 300 : PTFE filled spiral wound with inner ring.
- (2) Class 150 : S/S inserted flexible graphite sheet designed with permeation protective barrier  
Class 300 : Spiral wound flexible graphite with inner ring.

Series C:

- Class 150 : Flexible graphite sheet with stainless steel insert and permeation protective barrier for low emission service.
- Class 300 : Spiral wound (flexible graphite filler and stainless steel hoop) with a stainless steel inner ring

Class 600 : Ring joint metal gasket

### Diametrical interface clearance

- 20 to 32 mils (0.5 to 0.8 mm) : Stem to gland
- 20 to 32 mils (0.5 to 0.8 mm) : Stem to bonnet bushing (Series C)
- 16 to 28 mils (0.4 to 0.7 mm) : Stem to backseat (Series A, HA)
- 4 to 12 mils (0.1 to 0.3 mm) : Gland to stuffing box

### Stem

16 to 32 RMS surface finish. Straightness and roundness are precision controlled according to KITZ design and manufacturing standards.

### Stuffing box

Maximum 125 RMS surface finish. Cylindricity and verticality are precision controlled according to KITZ design and manufacturing standards.

### Product identification

Stainless steel ID plates with the letters "LOW EMISSION" in orange are welded on the bonnet flanges.



## Inspection and Warranty Policy of KITZ Corporation

Every piece of KITZ stainless and high alloy steel valves is subjected to 100% pressure tests, according to API 598 or BS 6755 Part 1 requirements. Manufacturer's material test reports and inspection certificates are available on your request, while each valve is guaranteed for 12 months after placement in service, but not exceeding 18 months after shipment from the factories of KITZ Corporation.

Various tests and inspection of valves made by KITZ Corporation include the following. Unless otherwise specified, all KITZ stainless and high alloy steel valves shall be subjected to these testing or inspection methods and evaluation criteria.

Test/Inspection Item	Method	Evaluation
Chemical composition analysis		Relevant ASTM Stds.
Mechanical property test	ASTM A370	Relevant ASTM Stds.
Pressure tests	API 598 or BS 6755 Part 1	API 598
Radiographic inspection	ASTM E142 / E49	
Wet magnetic particle inspection	ASTM E138	ASME B16.34
Liquid penetrant inspection	ASTM E165	
Low temperature impact test	ASTM E23	ASTM A352
Dimensional inspection		Relevant Valve Stds.
Visual inspection		MSS SP-55
Emission test*	EPA Method 21 and KITZ Std.	KITZ Std.

\*Applicable to low emission service valves.

## KITZ Low Temperature and Cryogenic Service Valves

KITZ Corporation offers Series A and C stainless steel gate, globe and check valves for processing, storage, shipment and distribution of ethylene, LPG, LNG and other low temperature or cryogenic fluid down to  $-196^{\circ}\text{C}$  ( $-321^{\circ}\text{F}$ ). Here, extended bonnets are provided as an insulation vapor column to protect gland packing rings from freezing or shrinking for their trouble-free sealing function. Detailed design information and cryogenic test reports are available on request.



KITZ cryogenic service gate valve

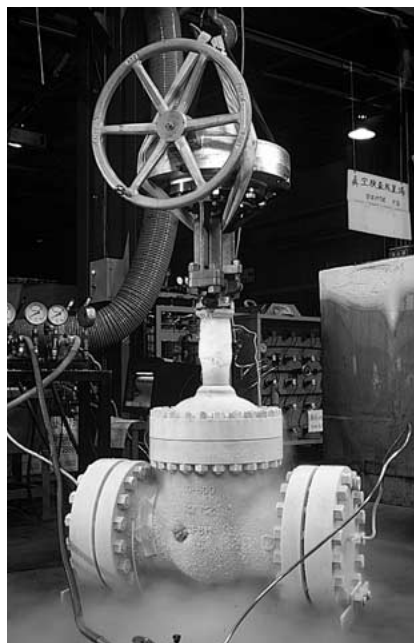

Cryogenic pressure test

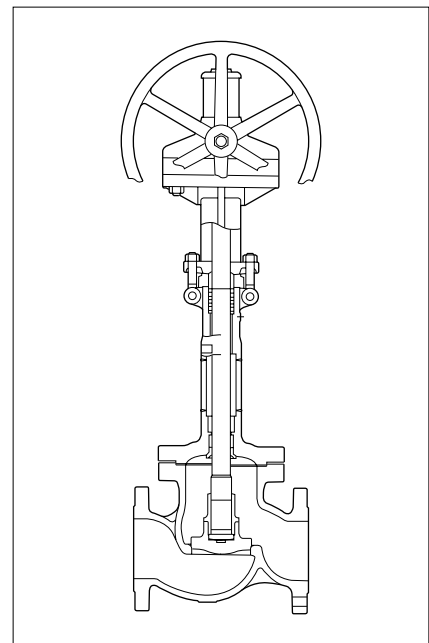

KITZ cryogenic service globe valve

**Class 150**

**GATE VALVE**

Pressure-Temperature Rating: ASME B 16.34

150UMA

150UMAM

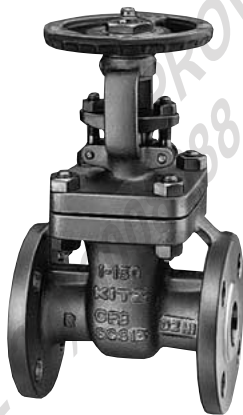
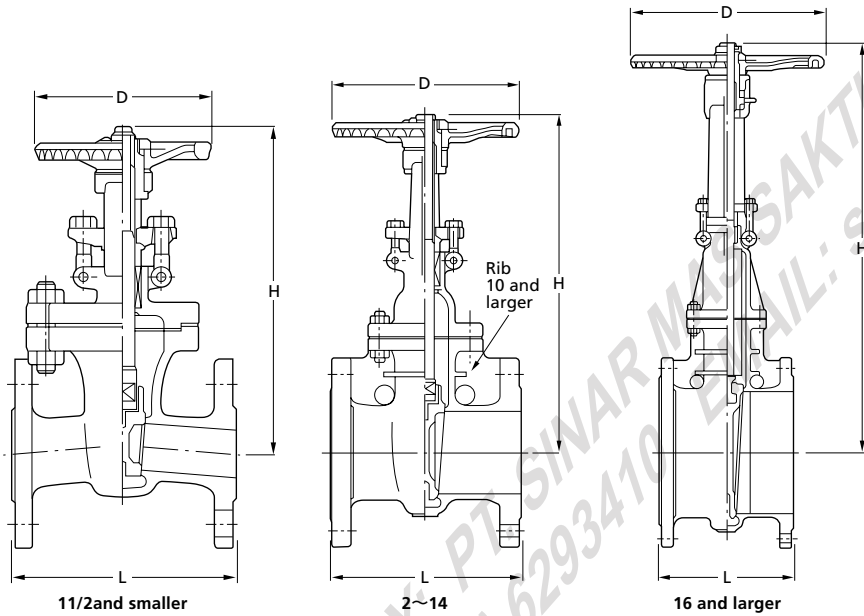

**150UMARM 21/2~4**  
with male-female round gasket face



**Materials**

Parts	150UMA	150UMAM
Body	CF8	CF8M
Bonnet	CF8	CF8M
Stem	304	316
Disc	CF8	CF8M
Gland	304	316
Gland flange	CF8	
Gland packing	Refer to Page 10	
Gasket	Refer to Page 10	
Yoke sleeve	Ductile Ni-resist	
Yoke**	Ductile iron	
Handwheel	Ductile iron	
Gland bolt/nut	B8/8	
Bonnet bolt/nut	B8/8	
Grease nipple***	Steel	
Name plate	Aluminum	

\*(T) Sufficing stands for the provision of ceramic filled PTFE gaskets.

\*\*Yoke is separated from bonnet for 10 and larger.

\*\*\*For size 10 and larger.

Note: • Body seats and/or disc seats can be optionally hard-faced.

• Size 1 1/4 is only for 10K.

• Flexible wedge for all sizes.

Items	
Face-to-Face Dimensions	ASME B16.10
End Flange Dimensions	ASME B16.5
Wall Thickness	ASME B16.34 Class 150

Nominal Size	1/2	3/4	1	1 1/2	2	2 1/2	3	4	5	6	8	10	12	14	16	18	20	24	
	15	20	25	40	50	65	80	100	125	150	200	250	300	350	400	450	500	600	
L	in.	4.25	4.26	5.00	6.50	7.00	7.50	8.00	9.00	10.00	10.50	11.50	13.00	14.00	15.00	16.00	17.00	18.00	20.00
	mm	108	117	127	165	178	190	203	229	254	267	292	330	356	381	406	432	457	508
H (open)	in.	7.8	8.2	8.8	11.1	13.2	14.8	17.5	20.6	23.9	28.0	36.2	44.0	52.1	58.5	66.5	74.4	82.7	96.9
	mm	198	208	224	282	336	375	445	523	606	710	920	1117	1324	1486	1690	1890	2100	2460
D	in.	3.5	3.5	3.9	5.5	6.3	7.1	7.9	8.9	9.8	9.8	11.8	13.8	15.8	17.7	23.6	23.6	26.8	29.9
	mm	90	90	100	140	160	180	200	225	250	250	300	350	400	450	600	600	680	760

**Class 300**

**GATE VALVE**

Pressure-Temperature Rating: ASME B 16.34

300UMA

300UMAM

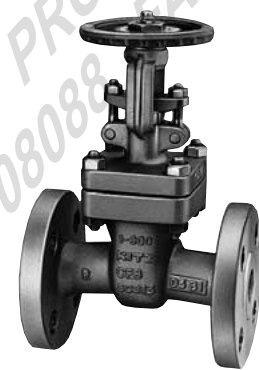
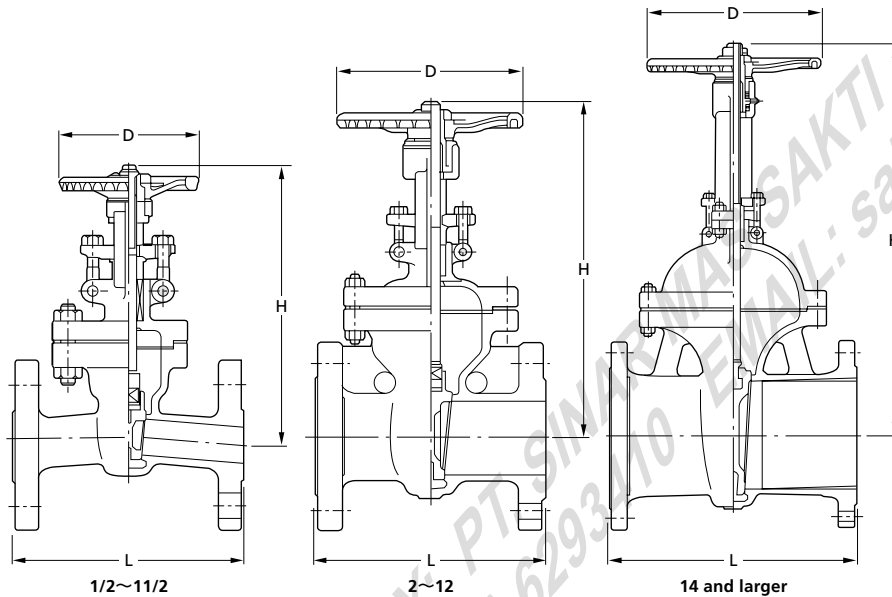

**Materials**

Parts	300UMA	300UMAM
Body	CF8	CF8M
Bonnet	CF8	CF8M
Stem	304	316
Disc	CF8	CF8M
Gland	304	316
Gland flange	CF8	
Gland packing	Refer to Page 10	
Gasket	Refer to Page 10	
Yoke*	Ductile iron	
Yoke sleeve	Ductile Ni-resist	
Handwheel	Ductile iron	
Gland bolt/nut	B8/8	
Gland bolt pin	403	
Bonnet bolt/nut	B8/8	
Grease nipple**	Carbon steel	
Name plate	Aluminum	

\*Yoke is separated from bonnet for size 10 and larger.

\*\*For size 10 and larger.

Note: • Body seats and/or disc seats can be optionally hard-faced.

• Flexible wedge for all sizes.

Items	
Face-to-Face Dimensions	ASME B16.10
End Flange Dimensions	ASME B16.5
Wall Thickness	ASME B16.34 Class 300

Nominal Size	1/2	3/4	1	1 1/2	2	2 1/2	3	4	5	6	8	10	12	14	16	18	20	24	
	15	20	25	40	50	65	80	100	125	150	200	250	300	350	400	450	500	600	
L	in.	5.50	6.00	6.50	7.50	8.50	9.50	11.12	12.00	15.00	15.88	16.50	18.00	19.75	30.00	33.00	36.00	39.00	45.00
	mm	140	152	165	190	216	241	283	305	381	403	419	457	502	762	838	914	991	1143
H (open)	in.	8.1	8.5	9.3	11.5	13.9	15.9	18.5	22.1	24.7	29.7	38.1	46.1	54.3	62.6	71.3	78.0	86.2	101.6
	mm	207	217	236	292	353	404	470	560	626	753	968	1170	1380	1590	1810	1980	2190	2580
D	in.	3.9	3.9	3.9	5.5	7.1	7.1	8.9	9.8	11.8	13.8	15.8	17.7	19.7	23.6	23.6	26.8	29.9	35.8
	mm	100	100	100	140	180	180	225	250	300	350	400	450	500	600	600	680	760	910

**Class 600**

**GATE VALVE**

Pressure-Temperature Rating: ASME B 16.34

600UMA

600UMAM

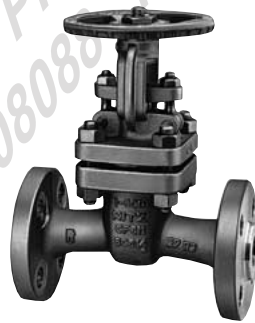
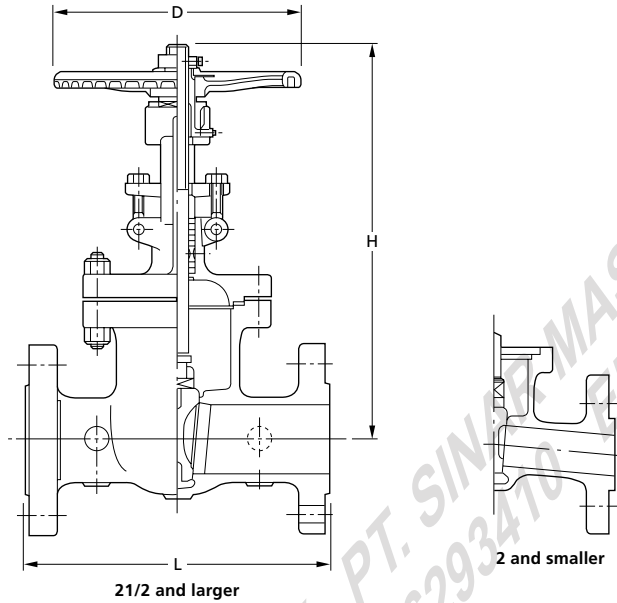

**Materials**

Parts	600UMA	600UMAM
Body	CF8	CF8M
Bonnet	CF8	CF8M
Stem	304	316
Disc*	CF8	CF8M
Gland	304	316
Gland flange	CF8	
Gland packing	Refer to Page 10	
Gasket	Refer to Page 10	
Yoke**	CF8	
Yoke sleeve	Ductile Ni-resist	
Handwheel	Ductile iron	
Gland bolt/nut	B8/8	
Gland bolt pin	403	
Bonnet bolt/nut	B8/8	
Grease nipple***	Carbon steel	
Thrust bearing****	Steel	
Collar***	304	316
Name plate	Aluminum	

\*Body seats and/or disc seats can be optionally hard-faced.

\*\*Yoke is separated from bonnet for size 8 and larger.

\*\*\*For size 2 and larger. \*\*\*\*For size 6 and larger.

Note: Flexible wedge for all sizes.

Items	
Face-to-Face Dimensions	ASME B16.10
End Flange Dimensions	ASME B16.5
Wall Thickness	ASME B16.34 Class 600

Nominal Size		1/2	3/4	1	1 1/2	2	2 1/2	3	4	6	8	10	12
		15	20	25	40	50	65	80	100	150	200	250	300
L	in.	6.50	7.50	8.50	9.50	11.50	13.00	14.00	17.00	22.00	26.00	31.00	33.00
	mm	165	190	216	241	292	330	356	432	559	660	787	838
H (open)	in.	8.1	8.7	9.8	13.2	17.7	18.9	21.4	26.6	35.6	44.5	52.3	60.0
	mm	207	222	250	335	450	480	544	676	905	1130	1328	1524
D	in.	3.9	3.9	5.5	7.1	7.9	8.9	9.8	13.8	17.7	19.7	23.6	26.8
	mm	100	100	140	180	200	225	250	350	450	500	600	680

10K

GATE VALVE

Pressure-Temperature Rating: JIS B2220

10UMA(T)

10UMAM(T)

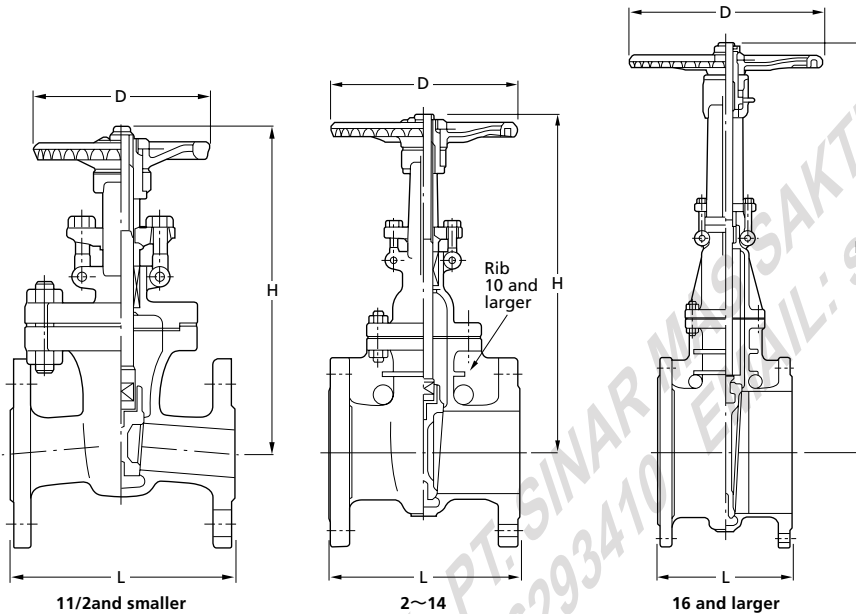

Materials

Parts	10UMA(T)	10UMAM(T)
Body	SCS13A	SCS14A
Bonnet	SCS13A	SCS14A
Stem	SUS304	SUS316
Disc	SCS13A	SCS14A
Gland	SUS304	SUS316
Gland flange	SCS13A	
Gland packing	Refer to Page 10	
Gasket	Refer to Page 10	
Yoke sleeve	Ductile Ni-resist	
Yoke**	FCD-5	
Handwheel	FCD400	
Gland bolt/nut	SUS304/304	
Bonnet bolt/nut	SUS304/304	
Grease nipple***	S20C	
Name plate	A1050P	

\*(T) Suffixing stands for the provision of ceramic filled PTFE gaskets.  
 \*\*Yoke is separated from bonnet for 10 and larger.  
 \*\*\*For size 10 and larger.  
 Note: \* Body seats and/or disc seats can be optionally hard-faced.  
       \* Size 1 1/4 is only for 10K.  
       \* Flexible wedge for all sizes.

Items	
Face-to-Face Dimensions	ASME B16.10
End Flange Dimensions	JIS B2220
Wall Thickness	ASME B16.34 Class 150

Nominal Size	1/2	3/4	1	1 1/4	1 1/2	2	2 1/2	3	4	5	6	8	10	12	14	16	18	20	24	
	15	20	25	32	40	50	65	80	100	125	150	200	250	300	350	400	450	500	600	
L	in.	4.25	4.26	5.00	5.50	6.50	7.00	7.50	8.00	9.00	10.00	10.50	11.50	13.00	14.00	15.00	16.00	17.00	18.00	20.00
	mm	108	117	127	140	165	178	190	203	229	254	267	292	330	356	381	406	432	457	508
H (open)	in.	7.8	8.2	8.8	9.4	11.1	13.2	14.8	17.5	20.6	23.9	28.0	36.2	44.0	52.1	58.5	66.5	74.4	82.7	96.9
	mm	198	208	224	238	282	336	375	445	523	606	710	920	1117	1324	1486	1690	1890	2100	2460
D	in.	3.5	3.5	3.9	3.9	5.5	6.3	7.1	7.9	8.9	9.8	9.8	11.8	13.8	15.8	17.7	23.6	23.6	26.8	29.9
	mm	90	90	100	100	140	160	180	200	225	250	250	300	350	400	450	600	600	680	760

TEL: (62 21) 6293410

PROVIDED BY: PT. SINAR MEGASAKTI  
 FAX: (62 21) 6293410  
 EMAIL: sales@smsakti.com

20K

GATE VALVE

Pressure-Temperature Rating: JIS B2220

20UMA

20UMAM

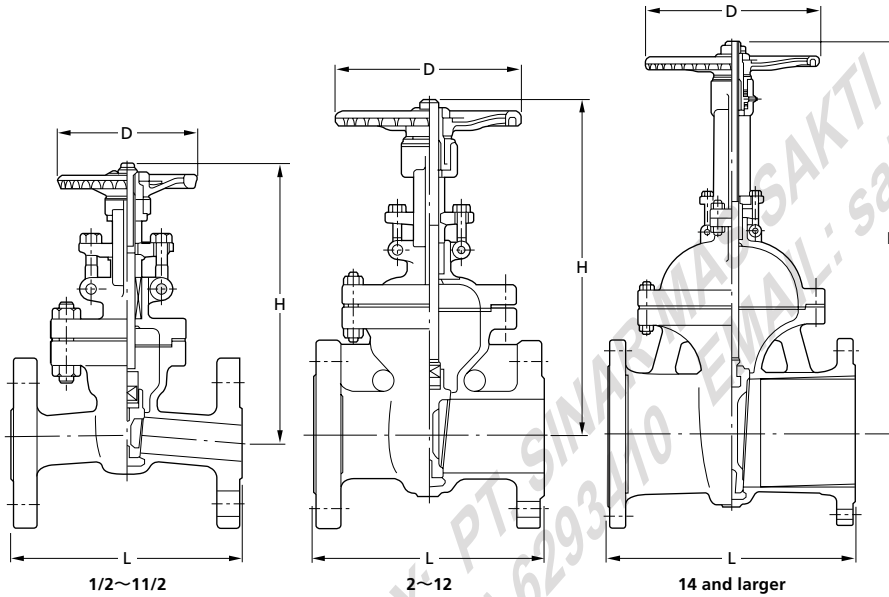

Materials

Parts	20UMA	20UMAM
Body	SCS13A	SCS14A
Bonnet	SCS13A	SCS14A
Stem	SUS304	SUS316
Disc	SCS13A	SCS14A
Gland	SUS304	SUS316
Gland flange	SCS13A	
Gland packing	Refer to Page 10	
Gasket	Refer to Page 10	
Yoke*	FCD-5	
Yoke sleeve	Ductile Ni-resist	
Handwheel	FCD400	
Gland bolt/nut	SUS304/304	
Gland bolt pin	SUS403	
Bonnet bolt/nut	SUS304/304	
Grease nipple**	S20C	
Name plate	A1050P	

\*Yoke is separated from bonnet for size 10 and larger.

\*\*For size 10 and larger.

Note: • Body seats and/or disc seats can be optionally hard-faced.

• Flexible wedge for all sizes.

Items	
Face-to-Face Dimensions	ASME B16.10
End Flange Dimensions	JIS B2220
Wall Thickness	ASME B16.34 Class 300

Nominal Size	1/2	3/4	1	1 1/2	2	2 1/2	3	4	5	6	8	10	12	14	16	18	20	24	
	15	20	25	40	50	65	80	100	125	150	200	250	300	350	400	450	500	600	
L	in.	5.50	6.00	6.50	7.50	8.50	9.50	11.12	12.00	15.00	15.88	16.50	18.00	19.75	30.00	33.00	36.00	39.00	45.00
	mm	140	152	165	190	216	241	283	305	381	403	419	457	502	762	838	914	991	1143
H (open)	in.	8.1	8.5	9.3	11.5	13.9	15.9	18.5	22.1	24.7	29.7	38.1	46.1	54.3	62.6	71.3	78.0	86.2	101.6
	mm	207	217	236	292	353	404	470	560	626	753	968	1170	1380	1590	1810	1980	2190	2580
D	in.	3.9	3.9	3.9	5.5	7.1	7.1	8.9	9.8	11.8	13.8	15.8	17.7	19.7	23.6	23.6	26.8	29.9	35.8
	mm	100	100	100	140	180	180	225	250	300	350	400	450	500	600	600	680	760	910

**Class 150**

**GLOBE VALVE**

Pressure-Temperature Rating: ASME B 16.34

150UPA

150UPAM

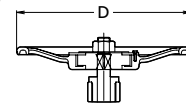
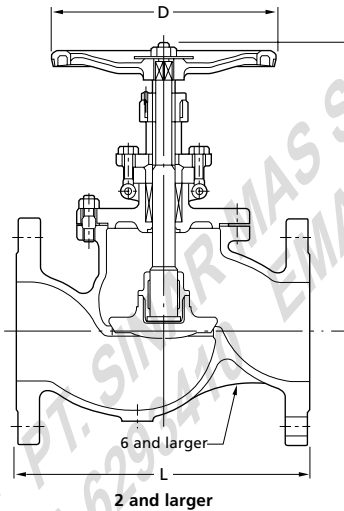
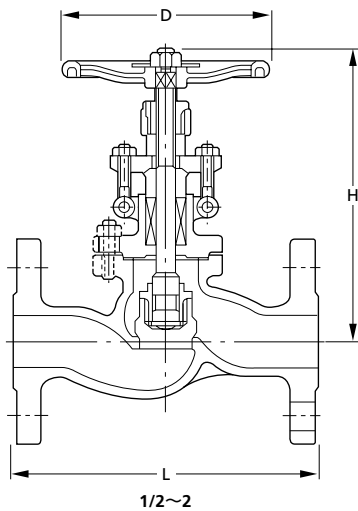

Hammer-blow Type Handwheel for 6 & 8

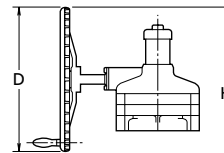

Gear Operation Standard for Nominal Size 10 & 12



**Materials**

Parts	150UPA	150UPAM
Body	CF8	CF8M
Bonnet	CF8	CF8M
Stem	304	316
Disc	1/2 to 2 2 1/2 to 12	304 CF8M
Disc holder	—	—
Gland	304	316
Gland flange	CF8	
Gland packing	Refer to Page 10	
Gasket	Refer to Page 10	
Yoke bush	Ductile Ni-resist	
Handwheel	Ductile iron	
Gland bolt/nut	B8/8	
Bonnet bolt/nut	B8/8	
Name plate	Aluminum	

Note: • Body seats and/or disc seats can be optionally hard-faced.  
 Hammer-blow type handwheel for 6 and 8

Items	
Face-to-Face Dimensions	ASME B16.10
End Flange Dimensions	ASME B16.5
Wall Thickness	ASME B16.34 Class 150

Nominal Size	1/2	3/4	1	1 1/2	2	2 1/2	3	4	5	6	8	10	12	
	15	20	25	40	50	65	80	100	125	150	200	250	300	
L	in.	4.25	4.26	5.00	6.50	8.00	8.50	9.50	11.50	14.00	16.00	19.50	24.50	27.50
	mm	108	117	127	165	203	216	241	292	356	406	495	622	698
H (open)	in.	7.8	6.6	6.8	8.1	9.3	9.8	11.5	12.8	15.0	17.8	22.0	40.7	41.4
	mm	168	168	173	205	235	248	291	325	380	453	559	1034	1051
D	in.	3.5	3.5	3.9	5.5	6.3	7.1	7.9	9.8	13.8	15.7	19.7	19.7	
	mm	90	90	100	140	160	180	200	225	250	350	400	500	

**Class 300**

**GLOBE VALVE**

Pressure-Temperature Rating: ASME B 16.34

300UPA

300UPAM

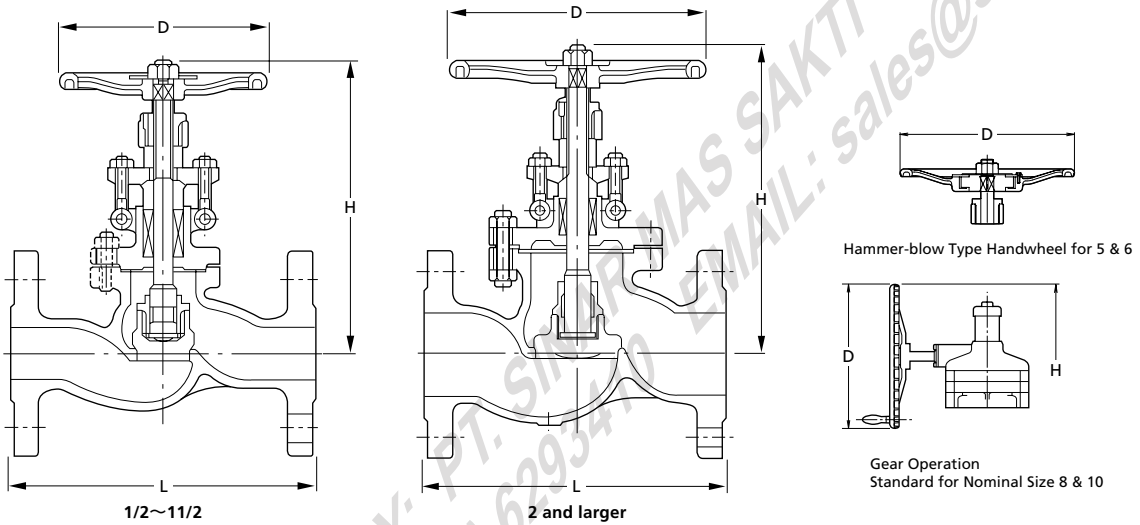

**Materials**

Parts	300UPA	300UPAM
Body	CF8	CF8M
Bonnet	CF8	CF8M
Stem	304	316
Disc	1/2 to 11/2 304	316
Lock nut	1/2 to 11/2 CF8	CF8M
	2 to 10 304	316
Gland	CF8	CF8M
Gland flange	304	316
Gland packing	CF8	
Gasket	Refer to Page 10	
Yoke bush	Refer to Page 10	
Handwheel	Ductile Ni-resist	
Gland bolt/nut	Ductile iron	
Gland bolt pin	B8/8	
Bonnet bolt/nut	403	
Name plate	B8/8	
	Aluminum	

Note: Body seats and/or disc seats can be optionally hard-faced.  
Hammer-blow type handwheel for size 5 and 6

Items	
Face-to-Face Dimensions	ASME B16.10
End Flange Dimensions	ASME B16.5
Wall Thickness	ASME B16.34 Class 300

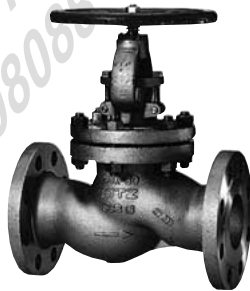

Nominal Size		1/2	3/4	1	1 1/2	2	2 1/2	3	4	5	6	8	10
		15	20	25	40	50	65	80	100	125	150	200	250
L	in.	6.00	7.00	8.00	9.00	10.50	11.50	12.50	14.00	15.75	17.50	22.00	24.50
	mm	152	178	203	229	267	292	318	356	400	444	559	622
H (open)	in.	9.3	7.3	7.4	9.3	11.4	11.7	13.5	15.7	19.4	22.2	34.8	41.5
	mm	186	186	187	236	289	297	343	398	493	564	883	1054
D	in.	3.9	3.9	3.9	6.3	7.1	7.9	9.8	11.8	13.8	15.8	19.7	23.6
	mm	100	100	100	160	180	200	250	300	350	400	500	600

**Class 600**

**GLOBE VALVE**

Pressure-Temperature Rating: ASME B 16.34

600UPA

600UPAM

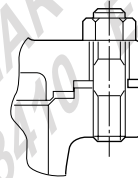
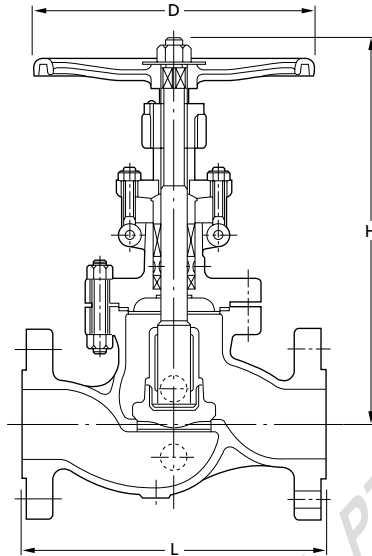

1/2 and smaller

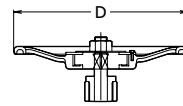

Hammer-blow Type Handwheel  
Standard for Nominal Size 3 & larger



**Materials**

Parts	600UPA	600UPAM
Body	CF8	CF8M
Bonnet	CF8	CF8M
Stem	304	316
Disc*	1/2 to 1 1/2 2 to 8	304 CF8 CF8M
Gland	304	316
Gland flange	CF8	
Gland packing	Refer to Page 10	
Gasket	Refer to Page 10	
Yoke bush	Ductile Ni-resist	
Handwheel	Ductile iron	
Gland bolt/nut	B8/8	
Bonnet bolt/nut	B8/8	
Collar**	304	316
Gland bolt pin	403	
Name plate	Aluminum	

\*Body seats and/or disc seats can be optionally hard-faced.

\*\*Size 2 and larger.

Hammer-blow type handwheel  
for size 3 and larger

Items	
Face-to-Face Dimensions	ASME B16.10
End Flange Dimensions	ASME B16.5
Wall Thickness	ASME B16.34 Class 600

Nominal Size	1/2	3/4	1	1 1/2	2	2 1/2	3	4	6	8	
		15	20	25	40	50	65	80	100	150	200
L	in.	6.50	7.50	8.50	9.50	11.50	13.00	14.00	17.00	22.00	26.00
	mm	165	190	216	241	292	330	356	432	559	660
H (open)	in.	8.0	8.3	9.6	11.1	14.6	17.4	19.3	23.0	29.2	34.5
	mm	203	210	245	282	372	441	490	584	742	877
D	in.	4.7	4.7	6.3	7.9	8.9	9.8	13.8	15.8	23.6	23.6
	mm	120	120	160	200	225	250	350	400	600	600

PROVIDED BY: PT. SINAR MAS SAKTI  
 TEL: (62 21) 6008088 FAX: (62 21) 6293440 EMAIL: sales@smsakti.com

10K

GLOBE VALVE

Pressure-Temperature Rating: JIS B2220

10UPA(T)

10UPAM(T)

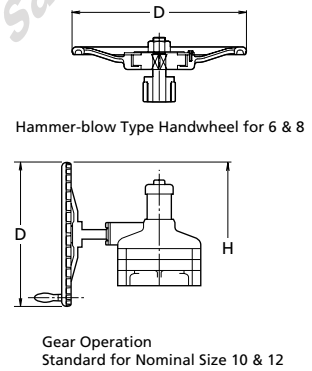
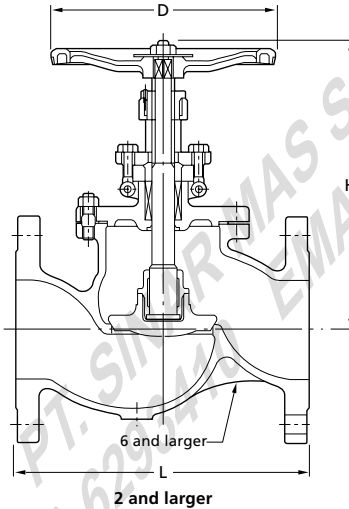
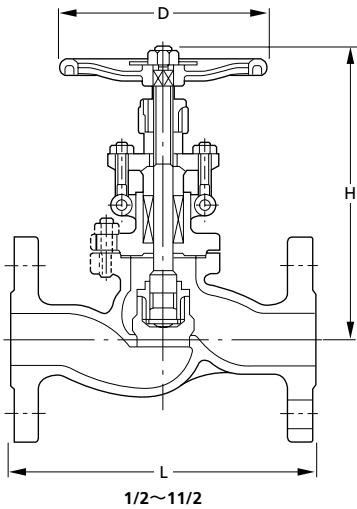

1/2~11/2

2 and larger

Materials

Parts	10UPA(T)*	10UPAM(T)*
Body	SCS13A	SCS14A
Bonnet	SCS13A	SCS14A
Stem	SUS304	SUS316
Disc	SUS304	SUS316
	1/2 to 2	
	2 1/2 to 12	
Disc holder	SCS13A/PTFE	SCS14A/PTFE
Gland	SUS304	SUS316
Gland flange	SCS13A	
Gland packing	Refer to Page 10	
Gasket	Refer to Page 10	
Yoke bush	Ductile Ni-resist	
Handwheel	FCD400	
Gland bolt/nut	SUS304/304	
Bonnet bolt/nut	SUS304/304	
Name plate	A1050P	

\*(T) Sufficing stands for the provision of ceramic filled PTFE gaskets.  
 Note: \* Body seats and/or disc seats can be optionally hard-faced.  
 Hammer-blow type handwheel for 6 and 8



Items	
Face-to-Face Dimensions	ASME B16.10
End Flange Dimensions	JIS B2220
Wall Thickness	ASME B16.34 Class 150

Nominal Size	1/2	3/4	1	1 1/4	1 1/2	2	2 1/2	3	4	5	6	8	10	12	
	15	20	25	32	40	50	65	80	100	125	150	200	250	300	
L	in.	4.25	4.26	5.00	5.50	6.50	8.00	8.50	9.50	11.50	14.00	16.00	19.50	24.50	27.50
	mm	108	117	127	140	165	203	216	241	292	356	406	495	622	698
H (open)	in.	7.8	6.6	6.8	7.5	8.1	9.3	9.8	11.5	12.8	15.0	17.8	22.0	35.4	41.4
	mm	198	168	173	190	205	235	248	291	325	380	453	559	1034	1051
D	in.	3.5	3.5	3.9	4.7	5.5	6.3	7.1	7.9	8.9	9.8	13.8	15.7	19.7	19.7
	mm	90	90	100	120	140	160	180	200	225	250	350	400	500	500

20K

SOFT SEATED GLOBE VALVE

Pressure-Temperature Rating: JIS B2220

20UPA

20UPAM

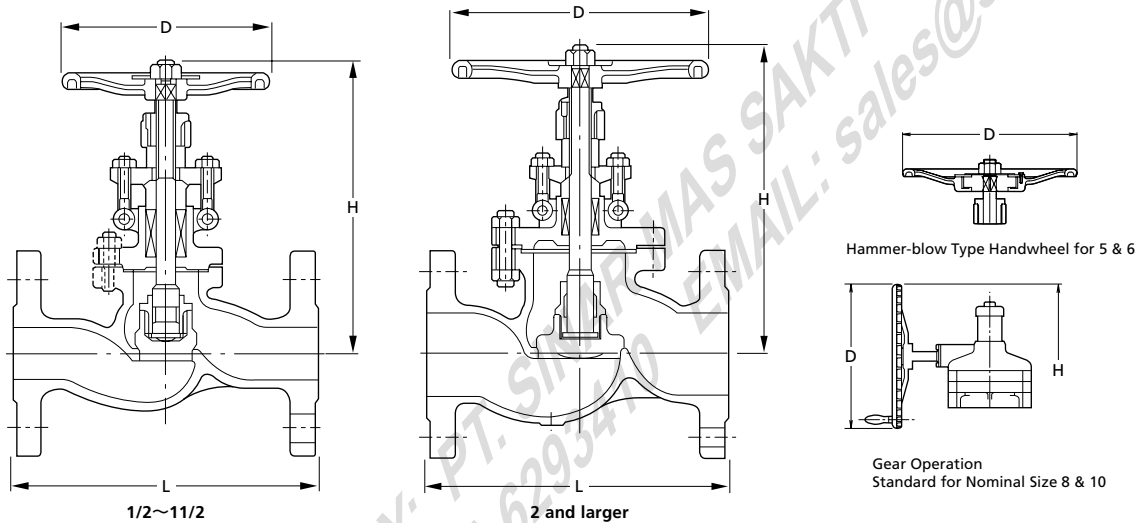

Materials

Parts	20UPA	20UPAM
Body	SCS13A	SCS14A
Bonnet	SCS13A	SCS14A
Stem	SUS304	SUS316
Disc	1/2 to 1 1/2	SUS304
	2 to 10	SCS13A
Lock nut	1/2 to 1 1/2	SUS304
	2 to 10	SCS13A
Gland	SUS304	SUS316
Gland flange	SCS13A	
Gland packing	Refer to Page 10	
Gasket	Refer to Page 10	
Yoke bush	Ductile Ni-resist	
Handwheel	FCD400	
Gland bolt/nut	SUS304/304	
Gland bolt pin	SUS403	
Bonnet bolt/nut	SUS304/304	
Name plate	A1050P	

Note: Body seats and/or disc seats can be optionally hard-faced.  
Hammer-blow type handwheel for size 5 and 6

Items	
Face-to-Face Dimensions	ASME B16.10
End Flange Dimensions	JIS B2220
Wall Thickness	ASME B16.34 Class 300

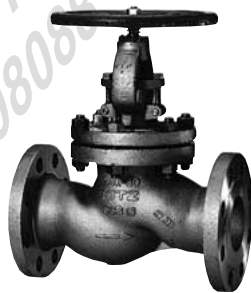

Nominal Size	1/2	3/4	1	1 1/2	2	2 1/2	3	4	5	6	8	10	
	15	20	25	40	50	65	80	100	125	150	200	250	
L	in.	6.00	7.00	8.00	9.00	10.50	11.50	12.50	14.00	15.75	17.50	22.00	24.50
	mm	152	178	203	229	267	292	318	356	400	444	559	622
H (open)	in.	9.3	7.3	7.4	9.3	11.4	11.7	13.5	15.7	19.4	22.2	34.8	41.5
	mm	186	186	187	236	289	297	343	398	493	564	883	1054
D	in.	3.9	3.9	3.9	6.3	7.1	7.9	9.8	11.8	13.8	15.8	19.7	23.6
	mm	100	100	100	160	180	200	250	300	350	400	500	600

10K

SOFT SEATED GLOBE VALVE

Pressure-Temperature Rating: JIS B2220

10UPDA

10UPDAM

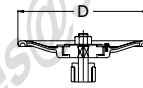
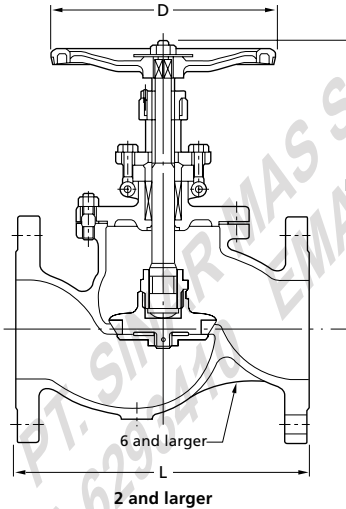
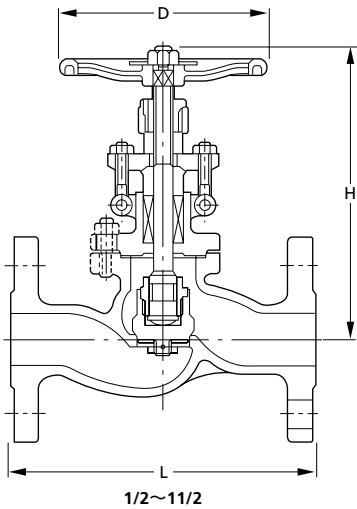

Hammer-blow Type Handwheel for 6 & 8

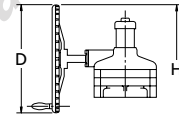

Gear Operation  
Standard for Nominal Size 10 & 12

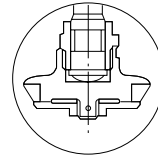

10UPDA/10UPDAM  
PTFE disc

Materials

Parts	10UPDA	10UPDAM
Body	SCS13A	SCS14A
Bonnet	SCS13A	SCS14A
Stem	SUS304	SUS316
Disc	PTFE**	PTFE**
Disc holder***	SUS304	SUS316
Gland	SUS304	SUS316
Gland flange	SCS13A	
Gland packing	Refer to Page 10	
Gasket	Refer to Page 10	
Yoke bush	Ductile Ni-resist	
Handwheel	FCD400	
Gland bolt/nut	SUS304/304	
Bonnet bolt/nut	SUS304/304	
Name plate	A1050P	

\*(T) Sufficing stands for the provision of ceramic filled PTFE gaskets.  
Note: • Body seats and/or disc seats can be optionally hard-faced.  
Hammer-blow type handwheel  
for 6 and 8



Items	
Face-to-Face Dimensions	ASME B16.10
End Flange Dimensions	JIS B2220
Wall Thickness	ASME B16.34 Class 150

Nominal Size	1/2	3/4	1	1 1/4	1 1/2	2	2 1/2	3	4	5	6	8	10	12	
		15	20	25	32	40	50	65	80	100	125	150	200	250	300
L	in.	4.25	4.26	5.00	5.50	6.50	8.00	8.50	9.50	11.50	14.00	16.00	19.50	24.50	27.50
	mm	108	117	127	140	165	203	216	241	292	356	406	495	622	698
H (open)	in.	7.8	6.6	6.8	7.5	8.1	9.3	9.8	11.5	12.8	15.0	17.8	22.0	35.4	41.4
	mm	198	168	173	190	205	235	248	291	325	380	453	559	1034	1051
D	in.	3.5	3.5	3.9	4.7	5.5	6.3	7.1	7.9	8.9	9.8	13.8	15.7	19.7	19.7
	mm	90	90	100	120	140	160	180	200	225	250	350	400	500	500

**Class 150**

**BELLOWS SEAL GLOBE VALVE**

Pressure-Temperature Rating: ASME B 16.34

150UPAW

150UPAWM

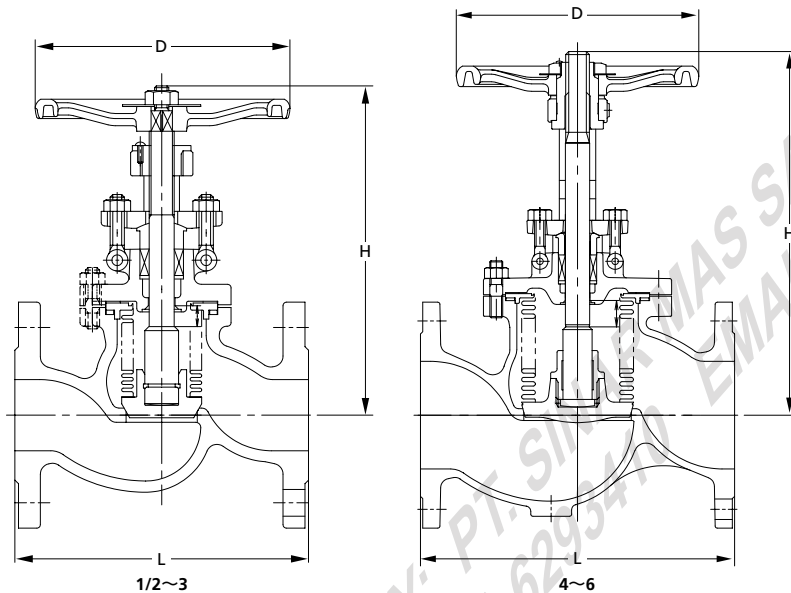

**Materials**

Parts	150UPAW	150UPAWM
Body	CF8	CF8M
Bonnet	CF8	CF8M
Stem	SUS304	
Disc	SUS316 or CF8M	
Lock nut	CF8	
Gland	SUS304	
Gland packing	Flexible graphite	
Hand wheel	Ductile Iron	
Name plate	Aluminum	
Gasket	Flexible graphite	
Packing washer	SUS304	
Bellows holder	SUS316	
Bellows	SUS316L	
Bonnet bolt/nut	B8/8	
Gland bolt/nut	B8/8	
Yoke sleeve	Ductile Ni-resist	

**Items**

Face-to-Face Dimensions	ASME B16.10
End Flange Dimensions	ASME B16.5
Wall Thickness	ASME B16.34

Nominal Size	1/2	3/4	1	1 1/2	2	2 1/2	3	4	5	6	
	15	20	25	40	50	65	80	100	125	150	
L	in.	4.25	4.62	5.00	6.50	8.00	8.50	9.50	11.50	14.00	16.00
	mm	108	117	127	165	203	216	241	292	356	406
H (open)	in.	6.54	6.54	6.66	7.92	9.10	9.61	11.15	14.30	16.74	19.00
	mm	166	166	169	201	231	244	283	363	425	482
D	in.	3.5	3.5	3.9	5.5	6.3	7.1	7.9	8.9	9.8	13.8
	mm	90	90	100	140	160	180	200	225	250	350

PROVIDED BY: PT. SIKRIMAS SAKTI  
 TEL: (62 21) 60080888 FAX: (62 21) 62934747 EMAIL: sales@smsakti.com

**Class 300**

**BELLOWS SEAL GLOBE VALVE**

Pressure-Temperature Rating: ASME B 16.34

300UPAW

300UPAWM

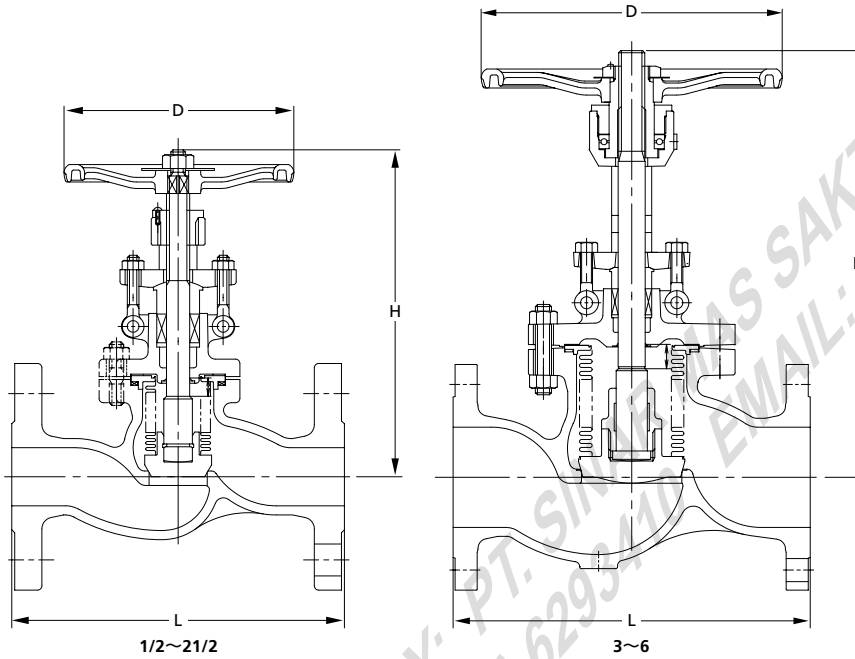

**Materials**

Parts	300UPAW	300UPAWM
Body	CF8	CF8M
Bonnet	CF8	CF8M
Stem	SUS304	
Disc	SUS316 or CF8M	
Gland	SUS304	
Gland packing	Flexible graphite	
Hand wheel	Ductile Iron	
Wheel nut	Carbon Steel	
Name plate	Aluminum	
Gasket	Flexible graphite	
Packing washer	SUS304	
Bellows holder	SUS316	
Bellows	SUS316L	
Bonnet bolt/nut	B8/8	
Gland bolt/nut	B8/8	
Yoke sleeve	Ductile Ni-resist	

**Items**

Face-to-Face Dimensions	ASME B16.10
End Flange Dimensions	ASME B16.5
Wall Thickness	ASME B16.34

Nominal Size	1/2	3/4	1	1 1/2	2	2 1/2	3	4	5	6	
	15	20	25	40	50	65	80	100	125	150	
<b>L</b>	in.	6.00	7.00	8.00	9.00	10.50	11.50	12.50	14.00	15.75	17.50
	mm	152	178	203	229	267	292	318	356	400	444
<b>H (open)</b>	in.	7.25	7.25	7.25	9.22	11.30	11.54	15.83	17.84	21.19	23.86
	mm	184	184	185	234	287	293	402	453	538	606
<b>D</b>	in.	3.9	3.9	3.9	6.3	7.1	7.9	9.8	11.8	13.8	15.8
	mm	100	100	100	160	180	200	250	300	350	400

10K

BELLOWS SEAL GLOBE VALVE

Pressure-Temperature Rating: JIS B2220

10UPAW

10UPAWM

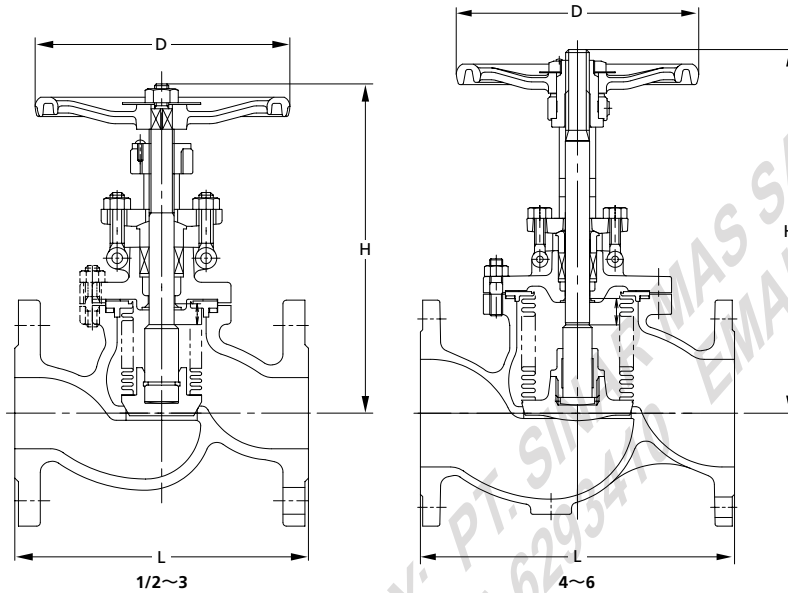

Materials

Parts	10UPAW	10UPAWM
Body	SCS13A	SCS14A
Bonnet	SCS13A	SCS14A
Stem	SUS304	
Disc	SUS316 or SCS14A	
Gland	SUS304	
Gland packing	Flexible graphite	
Hand wheel	FCD400	
Name plate	A1050P	
Gasket	Flexible graphite	
Packing washer	SUS304	
Bellows holder	SUS316	
Bellows	SUS316L	
Bonnet bolt/nut	SUS304	
Gland bolt/nut	SUS304	
Yoke sleeve	Ductile Ni-resist	

Items

Face-to-Face Dimensions	ASME B16.10
End Flange Dimensions	JIS B2220
Wall Thickness	ASME B16.34

Nominal Size		1/2	3/4	1	1 1/2	2	2 1/2	3	4	5	6
			15	20	25	40	50	65	80	100	125
L	in.	4.30	4.60	5.00	6.50	8.00	8.50	9.50	11.50	14.00	16.00
	mm	108	117	127	165	203	216	241	292	356	406
H (open)	in.	6.5	6.5	6.7	7.9	9.1	9.6	11.1	14.3	16.7	19.0
	mm	166	166	169	201	231	244	283	363	425	482
D	in.	3.5	3.5	3.9	5.5	6.3	7.1	7.9	8.9	9.8	13.8
	mm	90	90	100	140	160	180	200	225	250	350

20K

BELLOWS SEAL GLOBE VALVE

Pressure-Temperature Rating: JIS B2220

20UPAW

20UPAWM

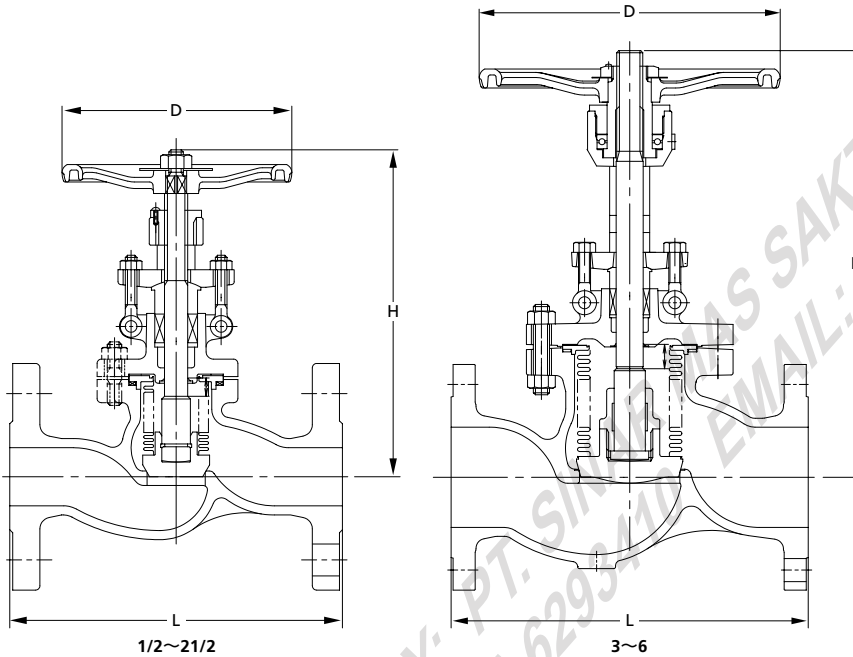

Materials

Parts	20UPAW	20UPAWM
Body	SCS13A	SCS14A
Bonnet	SCS13A	SCS14A
Stem	SUS304	
Disc	SUS316 or SCS14A	
Gland	SUS304	
Gland packing	Flexible graphite	
Hand wheel	FCD400	
Name plate	A1050P	
Gasket	Flexible graphite	
Packing washer	SUS304	
Bellows holder	SUS316	
Bellows	SUS316L	
Bonnet bolt/nut	SUS304	
Gland bolt/nut	SUS304	
Yoke sleeve	Ductile Ni-resist	

Items

Face-to-Face Dimensions	ASME B16.10
End Flange Dimensions	JIS B2220
Wall Thickness	ASME B16.34

Nominal Size	1/2	3/4	1	1 1/2	2	2 1/2	3	4	5	6	
	15	20	25	40	50	65	80	100	125	150	
L	in.	6.00	7.00	8.00	9.00	10.50	11.50	12.50	14.00	15.70	17.50
	mm	152	178	203	229	267	292	318	356	400	444
H (open)	in.	7.2	7.2	7.3	9.2	11.3	11.5	15.8	17.8	21.2	23.9
	mm	184	184	185	234	287	293	402	453	538	606
D	in.	3.9	3.9	3.9	6.3	7.1	7.9	9.8	11.8	13.8	15.7
	mm	100	100	100	160	180	200	250	300	350	400

**Class 150**

**SWING CHECK VALVE**

Pressure-Temperature Rating: ASME B 16.34

150UOA

150UOAM

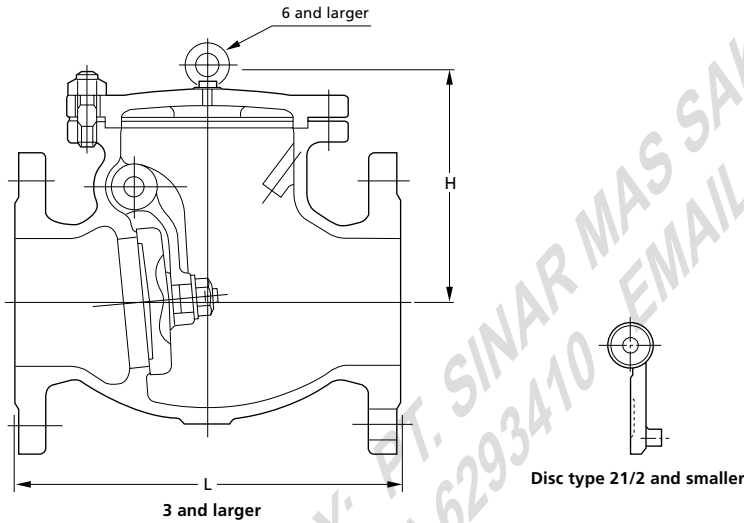

**Materials**

Parts	150UOA	150UOAM
Body	CF8	CF8M
Cover	CF8	CF8M
Disc	CF8	CF8M
Disc nutH	304	316
Gasket	Refer to Page 10	
Hinge pin	304	316
Plug	304	316
Arm	CF8	CF8M
Washer*	316, 316L (3~6)	
Cover bolt/nut	B8/8	
Split pin*	316L	

\*For size 3 and larger.

Note: Body seats and/or disc seats can be optionally hard-faced.



Items	
Face-to-Face Dimensions	ASME B16.10
End Flange Dimensions	ASME B16.5
Wall Thickness	ASME B16.34 Class 150

Nominal Size	1 1/2	2	2 1/2	3	4	5	6	8	10	12	14	16	18	20	24
		40	50	65	80	100	125	150	200	250	300	350	400	450	500
L	in.	6.50	8.00	8.50	9.50	11.50	13.00	14.00	19.50	24.50	27.50	31.00	34.00	38.50	51.00
	mm	165	203	216	241	292	330	356	495	622	698	787	864	978	1295
H	in.	4.2	4.7	5.3	5.8	6.7	7.5	8.4	9.96	11.0	12.3	16.0	16.1	18.7	23.4
	mm	107	120	135	147	169	190	213	253	279	312	407	410	475	595

**Class 300**

**SWING CHECK VALVE**

Pressure-Temperature Rating: ASME B 16.34

300UOA

300UOAM

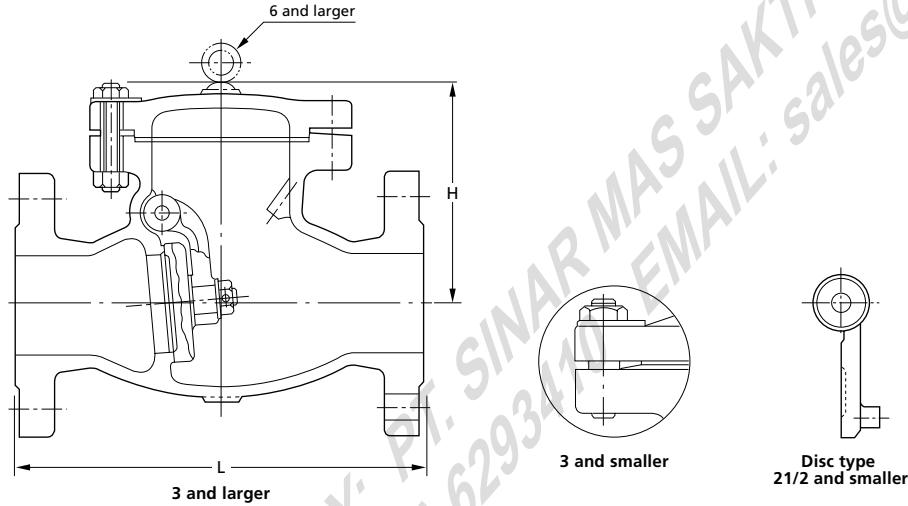

**Materials**

Parts	300UPA	300UPAM
Body	CF8	CF8M
Cover	CF8	CF8M
Disc	CF8	CF8M
Gasket	Refer to Page 10	
Disc nut*	304	316
Hinge pin	304	316
Plug	304	316
Arm*	CF8	CF8M
Washer*	316, 316L (3-6)	
Cover bolt/nut	B8/8	
Split pin	316L	

\*Size 3 and larger.  
Note: Body seats and/or disc seats can be optionally hard-faced.



Items	
Face-to-Face Dimensions	ASME B16.10
End Flange Dimensions	ASME B16.5
Wall Thickness	ASME B16.34 Class 300

Nominal Size	1 1/2	2	2 1/2	3	4	5	6	8	10	12	14	16	18	20	24	
	40	50	65	80	100	125	150	200	250	300	350	400	450	500	600	
<b>L</b>	in.	9.50	10.50	11.50	12.50	14.00	15.75	17.50	21.00	24.50	28.00	33.00	34.00	38.50	40.00	53.00
	mm	241	267	292	318	356	400	444	533	622	711	838	864	978	1016	1346
<b>H</b>	in.	4.6	5.3	6.3	7.1	7.9	9.1	10.0	11.6	13.2	14.8	17.2	18.9	23.0	23.8	24.8
	mm	117	135	160	180	200	230	255	295	335	375	437	480	585	605	630

**Class 600**

**SWING CHECK VALVE**

Pressure-Temperature Rating: ASME B 16.34

600UOA

600UOAM

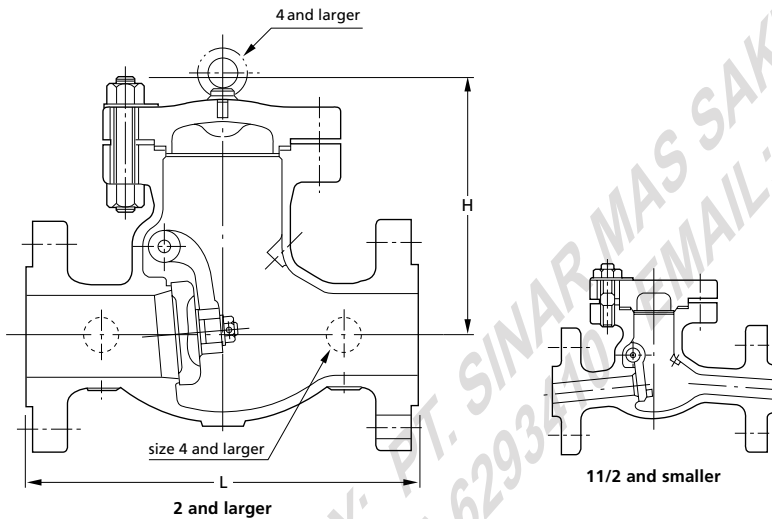

**Materials**

Parts	600UOA	600UOAM
Body	CF8	CF8M
Cover	CF8	CF8M
Disc*	CF8	CF8M
Gasket	Refer to Page 10	
Disc nut**	304	316
Hinge pin	304	316
Plug	304	316
Arm**	CF8	CF8M
Washer**	316, 316L (3-6)	316, 316L (3-6)
Cover bolt/nut	B8/8	
Split pin**	316L	
Name plate	Aluminum	

\*Body seats and/or disc seats can be optionally hard-faced.  
 \*\*Size 2 and larger.



Items	
Face-to-Face Dimensions	ASME B16.10
End Flange Dimensions	ASME B16.5
Wall Thickness	ASME B16.34 Class 600

Nominal Size	1/2	3/4	1	1 1/2	2	2 1/2	3	4	6	8	10	12	
	15	20	25	40	50	65	80	100	150	200	250	300	
<b>L</b>	in.	6.50	7.50	8.50	9.50	11.50	13.00	14.00	17.00	22.00	26.00	31.00	33.00
	mm	165	190	216	241	292	330	356	432	559	660	787	838
<b>H</b>	in.	3.5	3.8	4.1	4.7	7.1	8.1	9.3	10.6	13.0	15.8	16.9	18.5
	mm	90	95	105	120	180	205	235	270	330	400	430	470

10K

SWING CHECK VALVE

Pressure-Temperature Rating: JIS B2220

10UOA(T)

10UOAM(T)

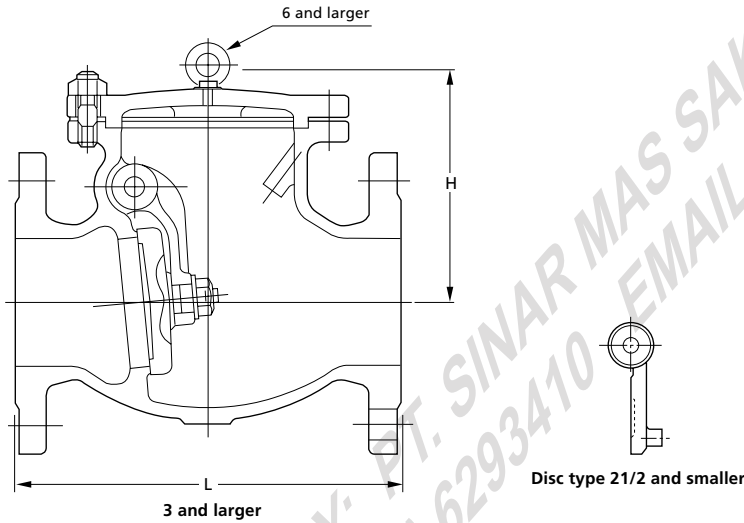

Materials

Parts	10UOA(T)*	10UOAM(T)*
Body	SCS13A	SCS14A
Cover	SCS13A	SCS14A
Disc	SCS13A	SCS14A
Disc nutH	SUS304	SUS316
Gasket	Refer to Page 6	
Hinge pin	SUS304	SUS316
Plug	SUS304	SUS316
Arm	SCS13A	SCS14A
WasherH	SUS316, SUS316L (3~6)	
Cover bolt/nut	SUS304/304	
Split pinH	SUS316L	

\*(T) Suffixing stands for the provision of ceramic filled PTFE gaskets.  
 \*For size 3 and larger.  
 Note: Body seats and/or disc seats can be optionally hard-faced.



Items	
Face-to-Face Dimensions	ASME B16.10
End Flange Dimensions	JIS B2220
Wall Thickness	ASME B16.34 Class 150

Nominal Size	1 1/2	2	2 1/2	3	4	5	6	8	10	12	14	16	18	20	24
		40	50	65	80	100	125	150	200	250	300	350	400	450	500
L	in.	6.50	8.00	8.50	9.50	11.50	13.00	14.00	19.50	24.50	27.50	31.00	34.00	38.50	51.00
	mm	165	203	216	241	292	330	356	495	622	698	787	864	978	1295
H	in.	4.2	4.7	5.3	5.8	6.7	7.5	8.4	9.96	11.0	12.3	14.3	16.0	18.7	23.4
	mm	107	120	135	147	169	190	213	253	279	312	364	407	475	595

20K

SWING CHECK VALVE

Pressure-Temperature Rating: JIS B2220

20UOA

20UOAM

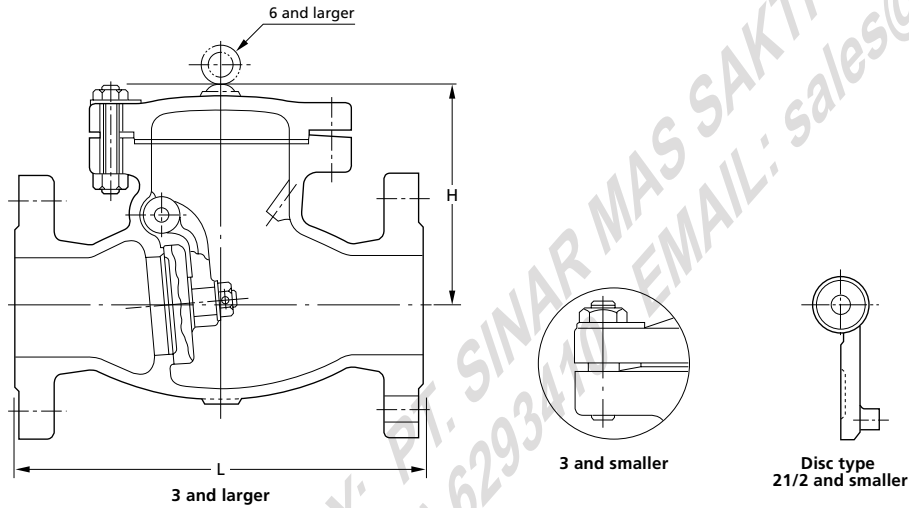

Materials

Parts	20UPA	20UPAM
Body	SCS13A	SCS14A
Cover	SCS13A	SCS14A
Disc	SCS13A	SCS14A
Gasket	Refer to Page 10	
Disc nut*	SUS304	SUS316
Hinge pin	SUS304	SUS316
Plug	SUS304	SUS316
Arm*	SCS13A	SCS14A
Washer*	SUS316, SUS316L (3~6)	
Cover bolt/nut	SUS304/304	
Split pin	SUS316L	

\*Size 3 and larger.

Note: Body seats and/or disc seats can be optionally hard-faced.



Items	
Face-to-Face Dimensions	ASME B16.10
End Flange Dimensions	JIS B2220
Wall Thickness	ASME B16.34 Class 300

Nominal Size		1 1/2	2	2 1/2	3	4	5	6	8	10	12	14	16	18	20	24
			40	50	65	80	100	125	150	200	250	300	350	400	450	500
L	in.	9.50	10.50	11.50	12.50	14.00	15.75	17.50	21.00	24.50	28.00	33.00	34.00	38.50	40.00	53.00
	mm	241	267	292	318	356	400	444	533	622	711	838	864	978	1016	1346
H	in.	4.6	5.3	6.3	7.1	7.9	9.1	10.0	11.6	13.2	14.8	17.2	18.9	23.0	23.8	24.8
	mm	117	135	160	180	200	230	255	295	335	375	437	480	585	605	630

**Class 150**

**LIFT CHECK VALVE**

Pressure-Temperature Rating: ASME B 16.34

150UNA

150UNAM

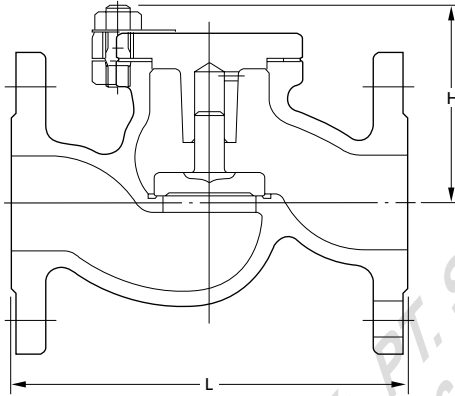

**Materials**

Parts	150UNA	150UNAM
Body	CF8	CF8M
Cover	CF8	CF8M
Disc	304	316
Gasket	Refer to Page 10	
Cover bolt/nut	B8/8	

\*(T) Suffixing stands for the provision of ceramic filled PTFE gaskets.  
 Note: \* Body seats and/or disc seats can be optionally hard-faced.  
 \* Size 1 1/4 is only for 10K.



Items	
Face-to-Face Dimensions	ASME B16.10
End Flange Dimensions	ASME B16.5
Wall Thickness	ASME B16.34 Class 150

Nominal Size	1/2		3/4		1		1 1/2	
	in.	mm	in.	mm	in.	mm	in.	mm
L	in.	4.25	in.	4.62	in.	5.00	in.	6.50
	mm	108	mm	117	mm	127	mm	165
H	in.	2.7	in.	2.8	in.	2.8	in.	3.3
	mm	68	mm	70	mm	70	mm	83

**Class 300**

**LIFT CHECK VALVE**

Pressure-Temperature Rating: ASME B 16.34

300UNA

300UNAM

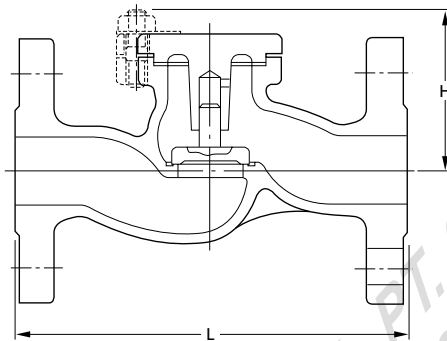

**Materials**

Parts	300UNA	300UNAM
Body	CF8	CF8M
Cover	CF8	CF8M
Disc	304	316
Gasket	Refer to Page 10	
Cover bolt/nut	B8/8	

Note: Body seats and/or disc seats can be optionally hard-faced.



Items	
Face-to-Face Dimensions	ASME B16.10
End Flange Dimensions	ASME B16.5
Wall Thickness	ASME B16.34 Class 300

Nominal Size	1/2		3/4		1		1 1/2	
	in.	mm	in.	mm	in.	mm	in.	mm
L	6.00	152	7.00	178	8.00	203	9.00	229
	2.9	73	2.9	73	2.9	73	3.5	90
H	2.9	73	2.9	73	2.9	73	3.5	90
	2.9	73	2.9	73	2.9	73	3.5	90

PROVIDED BY: PT. SINAR MAS SAKTI  
 TEL: (62 21) 6008088 FAX: (62 21) 6293410 EMAIL: sales@smsakti.com

10K

LIFT CHECK VALVE

Pressure-Temperature Rating: JIS B2220

10UNA(T)

10UNAM(T)

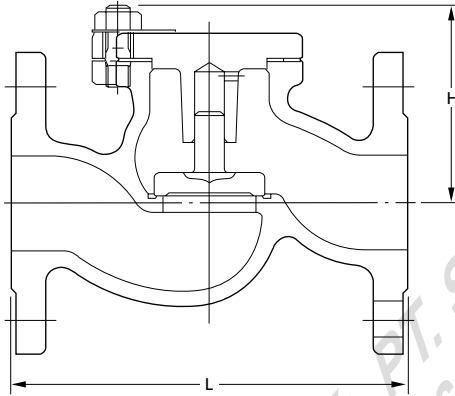

Materials

Parts	10UNA(T)*	10UNAM(T)*
Body	SCS13A	SCS14A
Cover	SCS13A	SCS14A
Disc	SUS304	SUS316
Gasket	Refer to Page 10	
Cover bolt/nut	SUS304/304	

\*(T) Suffixing stands for the provision of ceramic filled PTFE gaskets.

Note: \* Body seats and/or disc seats can be optionally hard-faced.

\* Size 1 1/4 is only for 10K.



Items	
Face-to-Face Dimensions	ASME B16.10
End Flange Dimensions	JIS B2220
Wall Thickness	ASME B16.34 Class 150

Nominal Size	1/2		3/4		1		1 1/4		1 1/2	
	in.	mm	in.	mm	in.	mm	in.	mm	in.	mm
L	4.25	108	4.62	117	5.00	127	5.50	140	6.50	165
	2.7	68	2.8	70	2.8	70	3.1	80	3.3	83
H	2.7	68	2.8	70	2.8	70	3.1	80	3.3	83
	2.7	68	2.8	70	2.8	70	3.1	80	3.3	83

20K

LIFT CHECK VALVE

Pressure-Temperature Rating: JIS B2220

20UNA

20UNAM

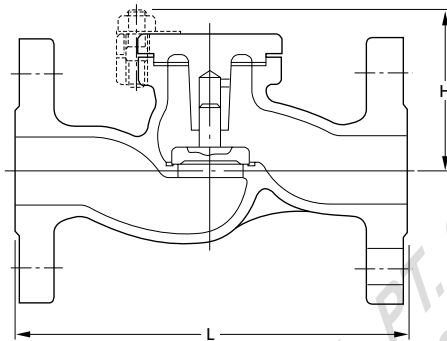

Materials

Parts	20UNA	20UNAM
Body	SCS13A	SCS14A
Cover	SCS13A	SCS14A
Disc	SUS304	SUS316
Gasket	Refer to Page 10	
Cover bolt/nut	SUS304/304	

Note: Body seats and/or disc seats can be optionally hard-faced.

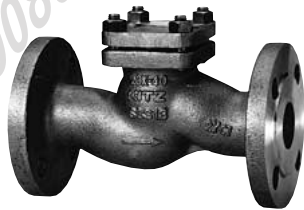

Items	
Face-to-Face Dimensions	ASME B16.10
End Flange Dimensions	JIS B2220
Wall Thickness	ASME B16.34 Class 300

Nominal Size	1/2		3/4		1		1 1/2	
	in.	mm	in.	mm	in.	mm	in.	mm
L	6.00	152	7.00	178	8.00	203	9.00	229
	2.9	73	2.9	73	2.9	73	3.5	90
H	2.9	73	2.9	73	2.9	73	3.5	90
	2.9	73	2.9	73	2.9	73	3.5	90

PROVIDED BY: PT. SINAR MAS SAKTI  
 TEL: (62 21) 6008088 FAX: (62 21) 6293410 EMAIL: sales@smsakti.com

10K

Y-PATTERN STRAINER

Pressure-Temperature Rating: JIS B2220

10UYA

10UYAM

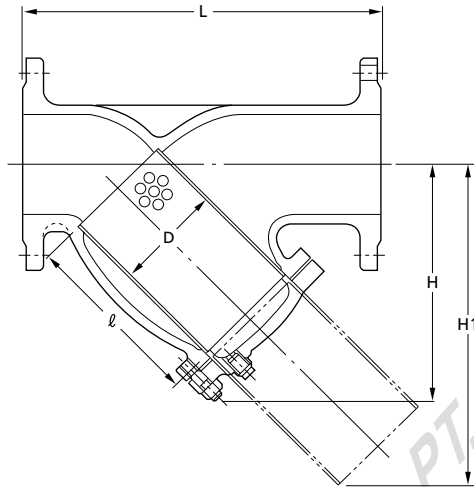

Materials

Parts	10UYA	10UYAM
Body	SCS13A	SCS14A
Cover	SCS13A	SCS14A
Gasket	Refer to Page 10	
Screen	SUS304	SUS316

Note: • Screen is a 40-mesh stainless wire net reinforced with a punched stainless steel plate.  
• Size 10 and larger for Fig. 10UYA(M).

Items	
End Flange Dimensions	JIS B2220 · ASME B16.5
Wall Thickness	ASME B16.34 Class 150

Nominal Size		2½	3	4	5	6	8	10	12
			65	65	100	125	150	200	250
L	in.	10.63	11.42	13.78	15.35	17.32	21.25	29.9	34.2
	mm	270	290	350	390	440	540	760	870
H	in.	6.2	7.8	9.2	105	12.6	15.0	21.2	25
	mm	160	197	233	267	320	380	538	635
H1	in.	8.5	10.4	12.6	15.0	17.8	21.9	28.5	34.3
	mm	215	263	320	383	452	555	725	870
D	in.	2.8	3.4	4.3	5.4	6.4	8.3	10.6	12.6
	mm	72	86	110	137	162	212	270	320
l	in.	4.72	5.91	7.09	8.46	10.04	12.20	15.7	18.90
	mm	120	150	180	215	255	310	400	480

**Class 150**

**GATE VALVE**

Pressure-Temperature Rating: ASME B 16.34

**150UMHAM**

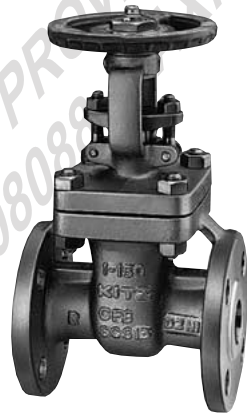
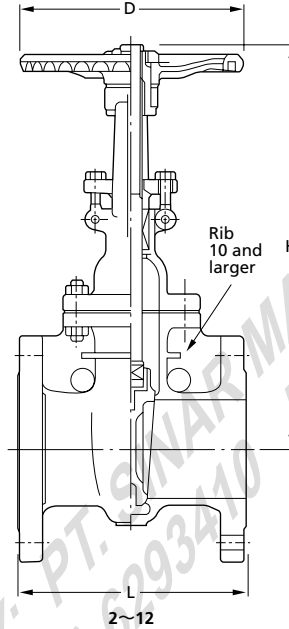
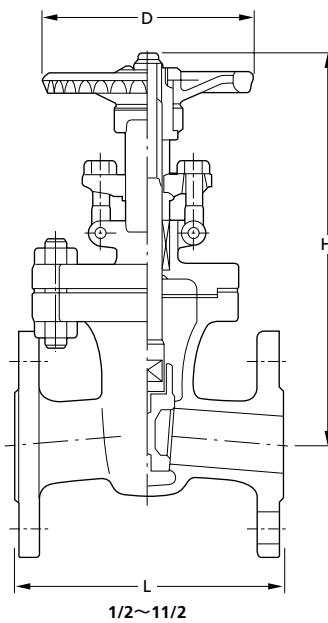

**Materials**

Parts	150UMHAM
Body	CF8M
Bonnet	CF8M
Stem	316
Disc	CF8M
Gland	316
Gland flange	CF8
Gland packing	Refer to Page 10
Gasket	Refer to Page 10
Yoke sleeve	Ductile Ni-resist
Yoke**	CF8
Handwheel	Ductile iron
Gland bolt/nut	B8/8
Bonnet bolt/nut	B8/8
Grease nipple***	Carbon Steel
Name plate	SUS304

\*\*Yoke is separated from bonnet for 10 and larger.  
 \*\*\*For size 10 and larger.  
 Note: \* Body seats and/or disc seats can be optionally hard-faced.  
 \* Flexible wedge for all sizes.

Items	
Face-to-Face Dimensions	ASME B16.10
End Flange Dimensions	ASME B16.5
Wall Thickness	API603

Nominal Size	1/2	3/4	1	1 1/2	2	2 1/2	3	4	6	8	10	12	
	15	20	25	40	50	65	80	100	150	200	250	300	
L	in.	4.25	4.62	5.00	6.50	7.00	7.50	8.00	9.00	10.50	11.50	13.00	14.00
	mm	108	117	127	165	178	190	203	229	267	292	330	356
H (open)	in.	7.8	8.2	8.8	11.1	13.2	14.8	17.5	20.6	28.0	36.2	44.3	52.6
	mm	198	208	224	282	336	375	445	523	710	920	1124	1335
D	in.	3.5	3.5	3.9	5.5	6.3	7.1	7.9	8.9	9.8	11.8	13.8	15.7
	mm	90	90	100	140	160	180	200	225	250	300	350	400

**Class 300**

**GATE VALVE**

Pressure-Temperature Rating: ASME B 16.34

300UMHAM

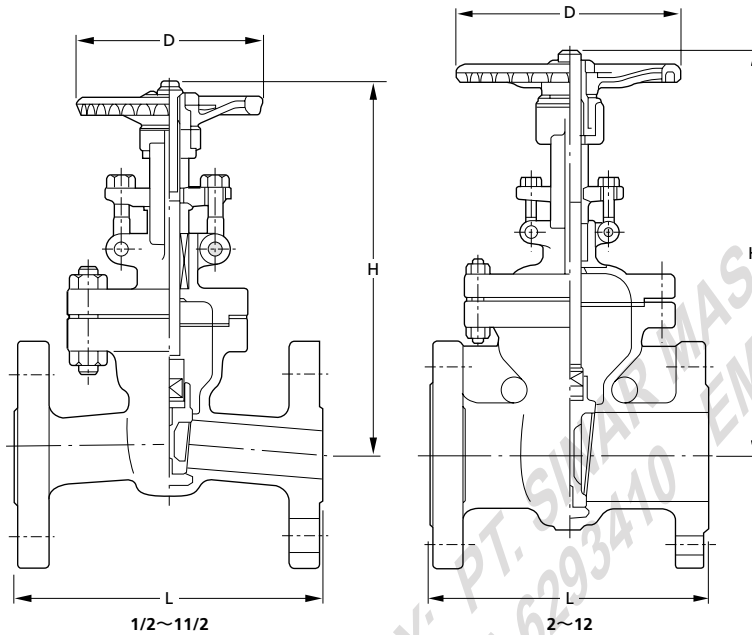

**Materials**

Parts	300UMHAM
Body	CF8M
Bonnet	CF8M
Stem	316
Disc	CF8M
Gland	316
Gland flange	CF8
Gland packing	Refer to Page 10
Gasket	Refer to Page 10
Yoke sleeve	Ductile Ni-resist
Yoke**	CF8
Handwheel	Ductile Iron
Gland bolt/nut	B8/8
Bonnet bolt/nut	B8/8
Grease nipple***	Carbon Steel
Name plate	SUS304

\*\*Yoke is separated from bonnet for size 10 and larger.

\*\*\*For size 10 and larger.

Note: • Body seats and/or disc seats can be optionally hard-faced.

• Flexible wedge for all sizes.

Items	
Face-to-Face Dimensions	ASME B16.10
End Flange Dimensions	ASME B16.5
Wall Thickness	API603

Nominal Size		1/2	3/4	1	1 1/2	2	2 1/2	3	4	6	8	10	12
		15	20	25	40	50	65	80	100	150	200	250	300
L	in.	5.50	6.00	6.50	7.50	8.50	9.50	11.12	12.00	15.88	16.50	18.00	19.75
	mm	140	152	165	190	216	241	283	305	403	419	457	502
H (open)	in.	8.1	8.5	10.6	12.7	14.0	16.0	18.5	22.0	29.6	38.1	46.1	54.3
	mm	207	217	269	323	355	406	470	560	752	966	1170	1380
D	in.	3.9	3.9	6.3	7.1	7.1	7.1	8.9	9.8	13.8	15.7	17.7	19.7
	mm	100	100	160	180	180	180	225	250	350	400	450	500

**Class 150**

**GATE VALVE**

Pressure-Temperature Rating: ASME B 16.34

150UMC

150UMCM

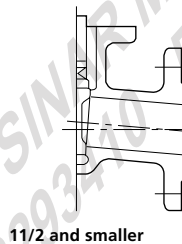
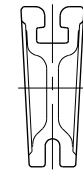
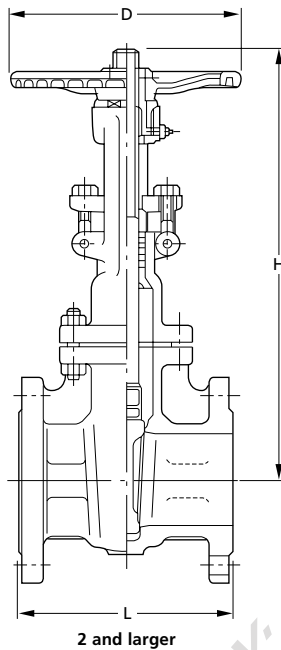

2 and larger



**Materials**

Parts	150UMC	150UMCM
Body*	CF8	CF8M
Bonnet	CF8	CF8M
Stem	304	316
Disc*	CF8	CF8M
Gland	304	316
Gland flange	CF8	
Gland packing	Refer to Page 10	
Gasket	Refer to Page 10	
Yoke**	CF8	
Yoke sleeve	Ductile Ni-resist	
Handwheel	Ductile iron	
Gland bolt/nut	B8/8	
Gland bolt pin	403	
Bonnet bolt/nut	B8/8	
Grease nipple	Carbon steel	
Name plate	Aluminum	

\*Body seats and/or disc seats can be optionally hard-faced.

\*\*Yoke is separated from bonnet for size 14 and larger.

Note: • Renewable seats are optionally available for size 2 and larger.

• Solid wedge for size 4 and smaller.

• Flexible wedge for all other sizes.

Items	
Face-to-Face Dimensions	ASME B16.10
End Flange Dimensions	ASME B16.5
Wall Thickness	API 600 Class150

Nominal Size	1/2	3/4	1	1 1/2	2	2 1/2	3	4	6	8	10	12	14	16	18	20	24	
	15	20	25	40	50	65	80	100	150	200	250	300	350	400	450	500	600	
L	in.	4.25	4.62	5.00	6.50	7.00	7.50	8.00	9.00	10.50	11.50	13.00	14.00	15.00	16.00	17.00	18.00	20.00
	mm	108	117	127	165	178	190	203	229	267	292	330	356	381	406	432	457	508
H (open)	in.	8.6	9.1	10.8	13.5	15.3	17.1	20.0	23.2	30.0	37.8	45.8	53.9	60.0	66.9	74.6	83.5	99.0
	mm	218	231	273	342	389	435	507	590	762	960	1164	1370	1523	1700	1895	2120	2515
D	in.	3.5	3.9	4.7	6.3	7.9	7.9	9.8	9.8	11.8	13.8	15.8	17.7	19.7	23.6	23.6	26.8	29.9
	mm	90	100	120	160	200	200	250	250	300	350	400	450	500	600	600	680	760

**Class 300**

**GATE VALVE**

Pressure-Temperature Rating: ASME B 16.34

300UMC

300UMCM

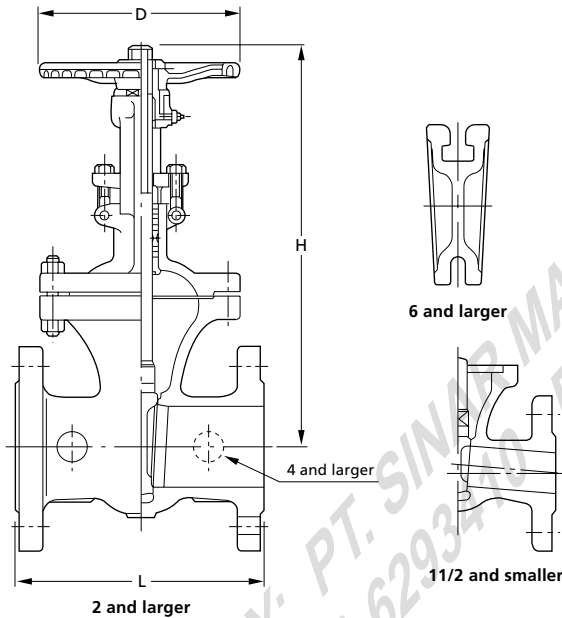

**Materials**

Parts	300UMC	300UMCM
Body*	CF8	CF8M
Bonnet	CF8	CF8M
Stem	304	316
Disc*	CF8	CF8M
Gland	304	316
Gland flange	CF8	
Gland packing	Refer to Page 10	
Gasket	Refer to Page 10	
Yoke**	CF8	
Yoke sleeve	Ductile Ni-resist	
Handwheel	Ductile iron	
Gland bolt/nut	B8/8	
Bonnet bolt/nut	B8/8	
Name plate	Aluminum	
Grease nipple	Carbon steel	
Collar	316	

\*Body seats and/or disc seats can be optionally hard-faced.

\*\*Yoke is separated from bonnet for size 12 and larger.

Note: • Renewable seats are optionally available for size 2 and larger.

• Solid wedge for size 4 and smaller.

• Flexible wedge for all other sizes.

**Items**

Face-to-Face Dimensions	ASME B16.10
End Flange Dimensions	ASME B16.5
Wall Thickness	API 600 Class300



Nominal Size	1/2	3/4	1	1 1/2	2	2 1/2	3	4	6	8	10	12	14	16	18	20	24
	15	20	25	40	50	65	80	100	150	200	250	300	350	400	450	500	600
<b>L</b>	5.50	6.00	6.50	7.50	8.50	9.50	11.10	12.00	15.90	16.50	18.00	19.80	30.00	33.00	36.00	39.00	45.00
	140	152	165	190	216	241	283	305	403	419	457	502	762	838	914	991	1143
<b>H (open)</b>	8.9	9.8	12.2	14.9	16.4	17.9	20.8	24.2	31.4	40.2	48.1	56.8	62.0	68.7	76.6	84.8	100.6
	227	250	310	378	416	455	528	615	798	1020	1222	1442	1575	1745	1945	2155	2555
<b>D</b>	3.9	3.9	4.7	7.9	7.9	7.9	9.8	9.8	13.8	15.7	17.7	19.7	23.6	23.6	26.8	29.9	35.8
	100	100	120	200	200	200	250	250	350	400	450	500	600	600	680	760	910

**Class 600**

**GATE VALVE**

Pressure-Temperature Rating: ASME B 16.34

600UMC

600UMCM

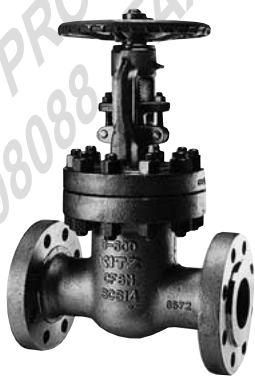
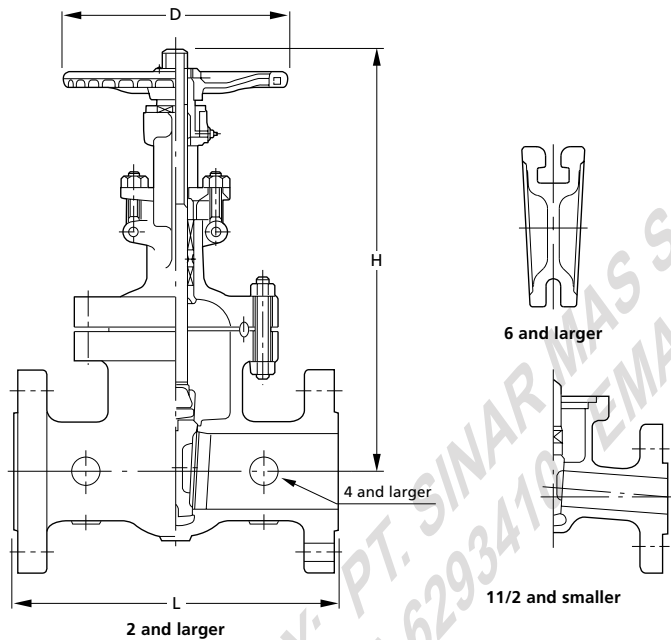

**Materials**

Parts	600UMC	600UMCM
Body*	CF8	CF8M
Bonnet	CF8	CF8M
Stem	304	316
Disc*	CF8	CF8M
Gland	304	316
Gland flange	CF8	
Gland packing	Refer to Page 10	
Gasket	Refer to Page 10	
Yoke**	CF8	
Yoke sleeve	Ductile Ni-resist	
Handwheel	Ductile iron	
Gland bolt/nut	B8/8	
Gland bolt pin	403	
Bonnet bolt/nut	B8/8	
Grease nipple	Carbon steel	
Name plate	Aluminum	

\*Body seats and/or disc seats can be optionally hard-faced.

\*\*Yoke is separated from bonnet for size 8 and larger.

Note: \* Renewable seats are optionally available for size 2 and larger.

- Solid wedge for size 1 & 1 1/2.
- Flexible wedge for all other sizes.

Items	
Face-to-Face Dimensions	ASME B16.10
End Flange Dimensions	ASME B16.5
Wall Thickness	API 600 Class600

Nominal Size	1/2	3/4	1	1 1/2	2	3	4	6	8	10	12	
	15	20	25	40	50	80	100	150	200	250	300	
L	in.	6.50	7.50	8.50	9.50	11.50	14.00	17.00	22.00	26.00	31.00	33.00
	mm	165	190	216	241	292	356	432	559	660	787	838
H (open)	in.	10.4	10.7	13.1	15.6	18.7	22.4	27.5	36.9	42.8	50.4	59.1
	mm	263	271	332	396	475	570	698	936	1087	1280	1500
D	in.	3.9	5.5	6.3	7.9	7.9	9.8	11.8	17.7	19.7	23.6	26.8
	mm	100	140	160	200	200	250	300	450	500	600	680

**Class 900**

**GATE VALVE**

Pressure-Temperature Rating: ASME B 16.34

900UMC

900UMCM

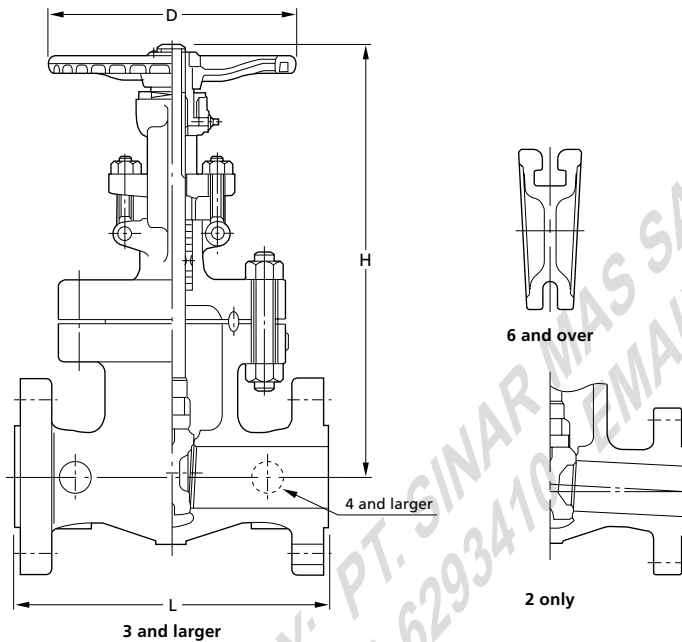

**Materials**

Parts	900UMC	900UMCM
Body*	CF8	CF8M
Bonnet	CF8	CF8M
Stem	304	316
Disc*	CF8	CF8M
Gland	304	316
Gland flange	CF8	
Gland packing	Refer to Page 10	
Gasket	Refer to Page 10	
Yoke**	CF8	
Yoke sleeve	Ductile Ni-resist	
Handwheel	Ductile iron	
Gland bolt/nut	B8/8	
Gland bolt pin	403	
Bonnet bolt/nut	B8/8	
Grease nipple	Carbon steel	
Name plate	304	

\*Body seats and/or disc seats can be optionally hard-faced.

\*\*Yoke is separated from bonnet for size 6 and larger.

Note: • All integral seats  
• All flexible wedges

Items	
Face-to-Face Dimensions	ASME B16.10
End Flange Dimensions	ASME B16.5
Wall Thickness	API 600 Class900

Nominal Size		2	3	4	6	8	10	12
			50	80	100	150	200	250
L	in.	14.50	15.00	18.00	24.00	29.00	33.00	38.00
	mm	368	381	457	610	737	838	965
H (open)	in.	21.0	24.4	27.7	36.1	43.6	51.7	60.2
	mm	523	620	704	916	1107	1313	1528
D	in.	9.8	11.8	13.8	19.7	23.6	26.8	29.9
	mm	250	300	350	500	600	680	760

**Class 1500**

**GATE VALVE**

Pressure-Temperature Rating: ASME B 16.34

1500UMC

1500UMCM

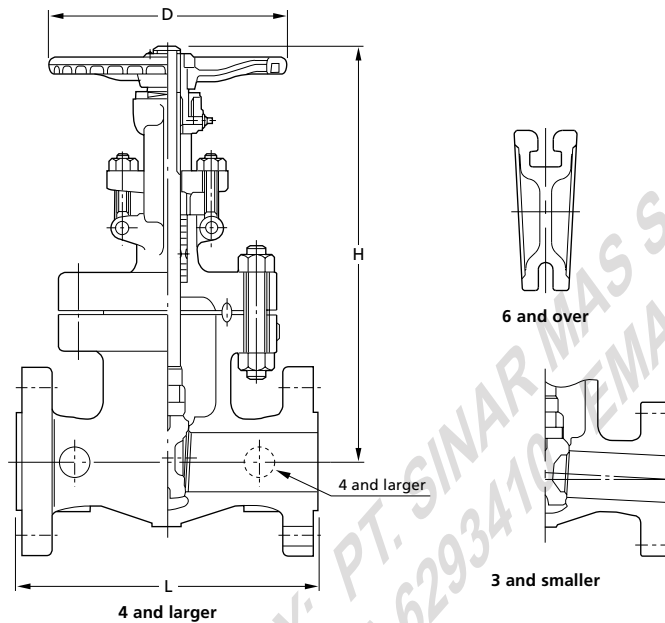

**Materials**

Parts	1500UMC	1500UMCM
Body*	CF8	CF8M
Bonnet	CF8	CF8M
Stem	304	316
Disc*	CF8	CF8M
Gland	304	316
Gland flange	CF8	
Gland packing	Refer to Page 10	
Gasket	Refer to Page 10	
Yoke**	CF8	
Yoke sleeve	Ductile Ni-resist	
Handwheel	Ductile iron	
Gland bolt/nut	B8/8	
Gland bolt pin	403	
Bonnet bolt/nut	B8/8	
Grease nipple	Carbon steel	
Name plate	304	

\*Body seats and/or disc seats can be optionally hard-faced.

\*\*Yoke is separated from bonnet for size 6 and larger.

Note: • All integral seats  
• All flexible wedges

Items	
Face-to-Face Dimensions	ASME B16.10
End Flange Dimensions	ASME B16.5
Wall Thickness	API 600 Class1500

Nominal Size		2	2½	3	4	6	8	10	12
			50	65	80	100	150	200	250
L	in.	14.50	16.50	18.50	21.50	27.75	32.75	39.00	44.50
	mm	368	419	470	546	705	832	991	1130
H (open)	in.	22.1	24.9	27.0	30.4	42.4	50.2	59.6	66.9
	mm	561	633	686	772	1078	1276	1513	1698
D	in.	9.8	11.8	13.8	15.8	23.6	26.8	35.8	35.8
	mm	250	300	350	400	600	680	910	910

**Class 150**

**GLOBE VALVE**

Pressure-Temperature Rating: ASME B 16.34

150UPC

150UPCM

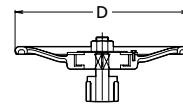
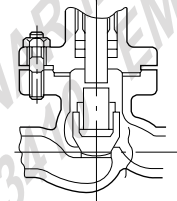
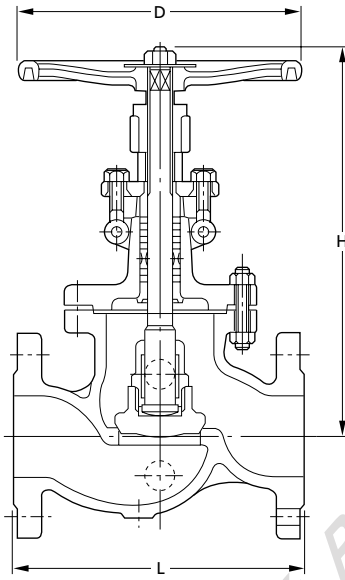

Hammer-blow Type Handwheel  
Standard for Nominal Size 6 & 8



**Materials**

Parts	150UPC	150UPCM
Body*	CF8	CF8M
Bonnet	CF8	CF8M
Stem	304	316
Disc*	CF8/304	CF8M/316
Lock nut	CF8/304	CF8M/316
Gland	304	316
Gland flange	CF8	
Gland packing	Refer to Page 10	
Gasket	Refer to Page 10	
Yoke bush	Ductile Ni-resist	
Handwheel	Ductile iron	
Gland bolt/nut	B8/8	
Gland bolt pin	403	
Bonnet bolt/nut	B8/8	
Name plate	Aluminum	

\*Body seats and/or disc seats can be optionally hard-faced.  
Note: Renewable seats are optionally available for size 2 and larger.  
Hammer-blow type handwheel for size 6 and 8

Items	
Face-to-Face Dimensions	ASME B16.10
End Flange Dimensions	ASME B16.5
Wall Thickness	API 600 Class150

Nominal Size		1/2	3/4	1	1 1/2	2	2 1/2	3	4	6	8
			15	20	25	40	50	65	80	100	150
L	in.	4.25	4.62	5.00	6.50	8.00	8.50	9.50	11.50	16.00	19.50
	mm	108	117	127	165	203	216	241	292	406	495
H (open)	in.	7.7	8.0	9.1	10.8	12.9	14.1	15.4	17.95	19.9	24.1
	mm	196	202	233	273	328	359	390	456	506	613
D	in.	3.5	3.9	4.7	6.3	7.9	8.9	9.8	9.8	13.8	15.8
	mm	90	100	120	160	200	225	250	250	350	400

**Class 300**

**GLOBE VALVE**

Pressure-Temperature Rating: ASME B 16.34

300UPC

300UPCM

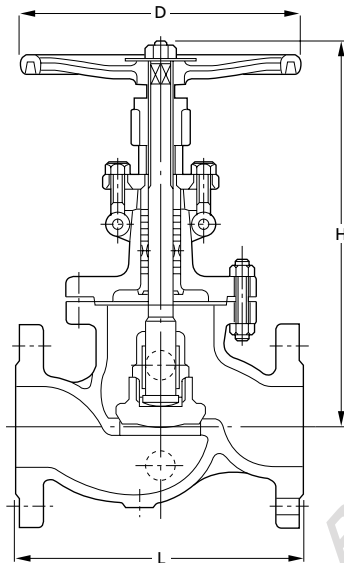

Disc 2 and larger

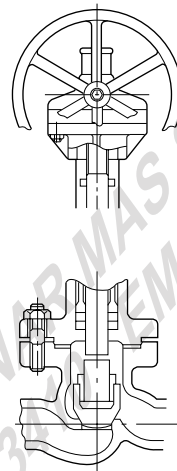

Disc 1 1/2 and smaller

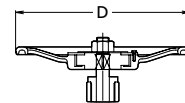

Hammer-blow Type Handwheel for 6

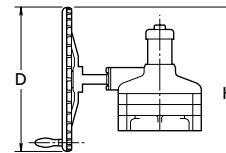

Gear Operation  
Standard for Nominal Size 8 & 10

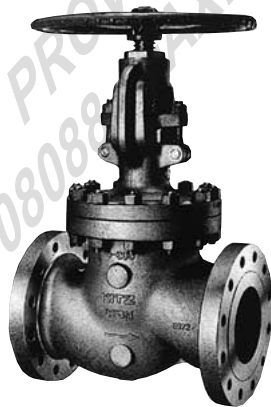

**Materials**

Parts	300UPC	300UPCM
Body*	CF8	CF8M
Bonnet	CF8	CF8M
Stem	304	316
Disc*	CF8/304	CF8M/316
Lock nut	CF8/304	CF8M/316
Gland	316	
Gland flange	CF8	
Gland packing	Refer to Page 10	
Gasket	Refer to Page 10	
Yoke bush	Ductile Ni-resist	
Handwheel	Ductile iron	
Gland bolt/nut	B8/8	
Gland bolt pin	403	
Bonnet bolt/nut	B8/8	
Name plate	Aluminum	
Collar	316	

\*Body seats and/or disc seats can be optionally hard-faced.  
Note: Renewable seats are optionally available for size 2 and larger.  
Gear operation for size 8 to 12 Hammer-blow type handwheel for size 6

Items	
Face-to-Face Dimensions	ASME B16.10
End Flange Dimensions	ASME B16.5
Wall Thickness	API 600 Class300

Nominal Size	1/2	3/4	1	1 1/2	2	2 1/2	3	4	6	8	
	15	20	25	40	50	65	80	100	150	200	
L	in.	6.00	7.00	8.00	9.00	10.50	11.50	12.50	14.00	17.50	22.00
	mm	152	178	203	229	267	292	318	356	444	559
H (open)	in.	8.7	8.9	10.1	11.9	13.9	15.8	17.3	20.0	26.7	41.9
	mm	220	222	259	302	352	400	440	509	677	1064
D	in.	3.9	3.9	5.5	7.1	7.9	9.8	9.8	13.8	17.7	19.7
	mm	100	100	140	180	200	250	250	350	450	500

**Class 600**

**GLOBE VALVE**

Pressure-Temperature Rating: ASME B 16.34

600UPC

600UPCM

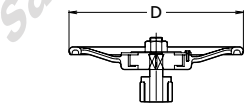
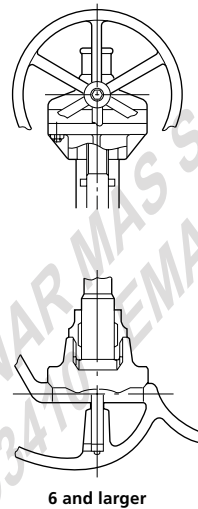
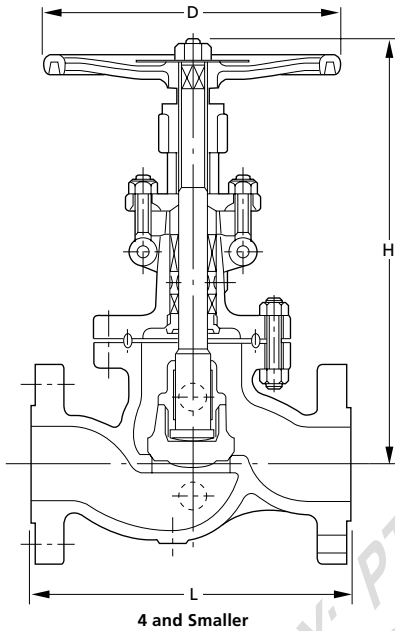

Hammer-blow Type Handwheel for 3

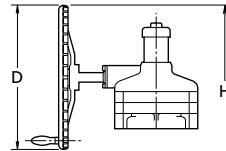

Gear Operation  
Standard for Nominal Size 4 & larger



**Materials**

Parts	600UPC	600UPCM
Body*	CF8	CF8M
Bonnet	CF8	CF8M
Stem	304	316
DiscH	304/CF8	316/CF8M
Lock nut	304/CF8	316/CF8M
Gland	316	
Gland flange	CF8	
Gland packing	Refer to Page 10	
Gasket	Refer to Page 10	
Yoke bush	Ductile Ni-resist	
Handwheel	Ductile iron	
Gland bolt/nut	B8/8	
Gland bolt pin	403	
Bonnet bolt/nut	B8/8	
Name plate	Aluminum	

\*Body seats and/or disc seats can be optionally hard-faced.  
Note: Renewable seats are optionally available for size 2 and larger.

**Gear operation**  
for size 4 to 8  
**Hammer-blow type handwheel**  
for size 3

Items	
Face-to-Face Dimensions	ASME B16.10
End Flange Dimensions	ASME B16.5
Wall Thickness	API 600 Class600

Nominal Size		1/2	3/4	1	1 1/2	2	3	4	6	8
			15	20	25	40	50	80	100	150
L	in.	6.50	7.50	8.50	9.50	11.50	14.00	17.00	22.00	26.00
	mm	165	190	216	241	292	356	432	559	660
H (open)	in.	11.0	10.8	11.4	13.4	16.3	20.8	37.3	40.6	48.5
	mm	280	275	290	340	413	529	947	1031	1232
D	in.	5.5	5.5	6.3	7.9	9.8	13.8	19.5	19.7	23.6
	mm	140	140	160	200	250	350	500	500	600

**Class 900**

**GLOBE VALVE**

Pressure-Temperature Rating: ASME B 16.34

900UPC

900UPCM

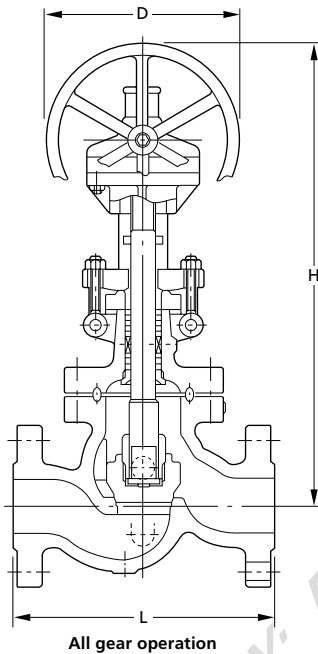

**Materials**

Parts	900UPC	900UPCM
Body*	CF8	CF8M
Bonnet	CF8	CF8M
Stem	304	316
Disc*	CF8	CF8M
Lock nut	CF8	CF8M
Gland	304	316
Gland flange	CF8	
Gland packing	Refer to Page 10	
Gasket	Refer to Page 10	
Yoke**	CF8	
Yoke bush	Ductile Ni-resist	
Handwheel	Ductile iron	
Gland bolt/nut	B8/8	
Gland bolt pin	403	
Bonnet bolt/nut	B8/8	
Name plate	304	

\*Body seats and/or disc seats can be optionally hard-faced.

\*\*Yoke is separated from bonnet for size 4 and larger.

Note: All integral seats

Items	
Face-to-Face Dimensions	ASME B16.10
End Flange Dimensions	ASME B16.5
Wall Thickness	API 600 Class900

Nominal Size	3	4	6	
	80	100	150	
<b>L</b>	in.	15.00	18.00	24.00
	mm	381	457	610
<b>H (open)</b>	in.	34.6	36.7	46.1
	mm	880	933	1171
<b>D</b>	in.	19.7	19.7	23.6
	mm	500	500	600

PROVIDED BY: PT. SINAR MAS SAKTI  
 TEL: (62 21) 6008088 FAX: (62 21) 6293410 EMAIL: sales@smsakti.com

**Class 1500**

**GLOBE VALVE**

Pressure-Temperature Rating: ASME B 16.34

1500UPC

1500UPCM

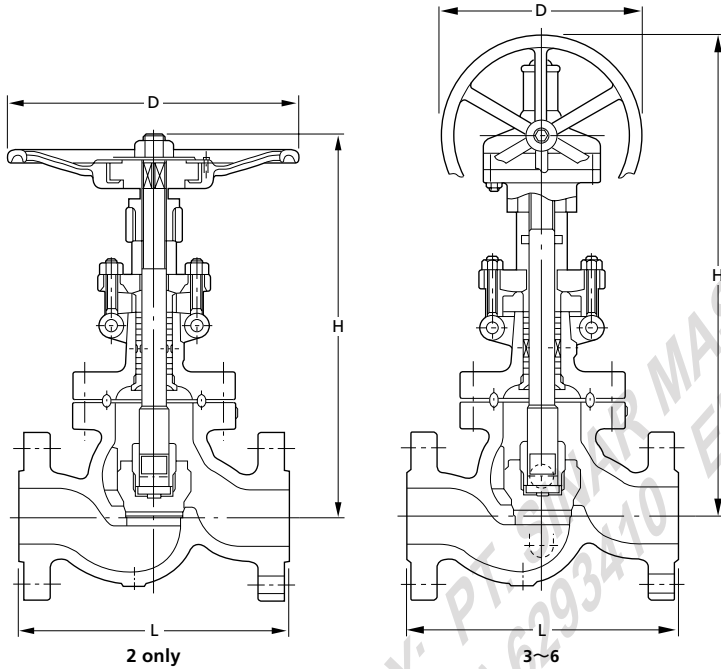

Gear Operation  
Standard for Nominal Size 3 & larger  
Hammer-blow Type Handwheel for 2

**Materials**

Parts	1500UPC	1500UPCM
Body*	CF8	CF8M
Bonnet	CF8	CF8M
Stem	304	316
Disc*	CF8	CF8M
Lock nut	CF8	CF8M
Gland	304	316
Gland flange	CF8	
Gland packing	Refer to Page 10	
Gasket	Refer to Page 10	
Yoke bush	Ductile Ni-resist	
Handwheel	Ductile iron	
Gland bolt/nut	B8/8	
Gland bolt pin	403	
Bonnet bolt/nut	B8/8	
Yoke**	CF8	
Name plate	304	

\*Body seats and/or disc seats can be optionally hard-faced.

\*\*Yoke is separated from bonnet for size 3 and larger.

Note: All integral seats

**Gear operation** for size 2 1/2 to 6      **Hammer-blow type handwheel** for size 2

Items	
Face-to-Face Dimensions	ASME B16.10
End Flange Dimensions	ASME B16.5
Wall Thickness	API 600 Class1500

Nominal Size	2		3		4		6	
	in.	mm	in.	mm	in.	mm	in.	mm
L	in.	14.50	in.	18.50	in.	21.50	in.	27.75
	mm	368	mm	470	mm	546	mm	705
H (open)	in.	21.5	in.	37.2	in.	43.4	in.	53.8
	mm	546	mm	946	mm	1102	mm	1366
D	in.	13.8	in.	19.7	in.	23.6	in.	23.6
	mm	350	mm	500	mm	600	mm	600

**Class 150**

**SWING CHECK VALVE**

Pressure-Temperature Rating: ASME B 16.34

150UOC

150UOCM

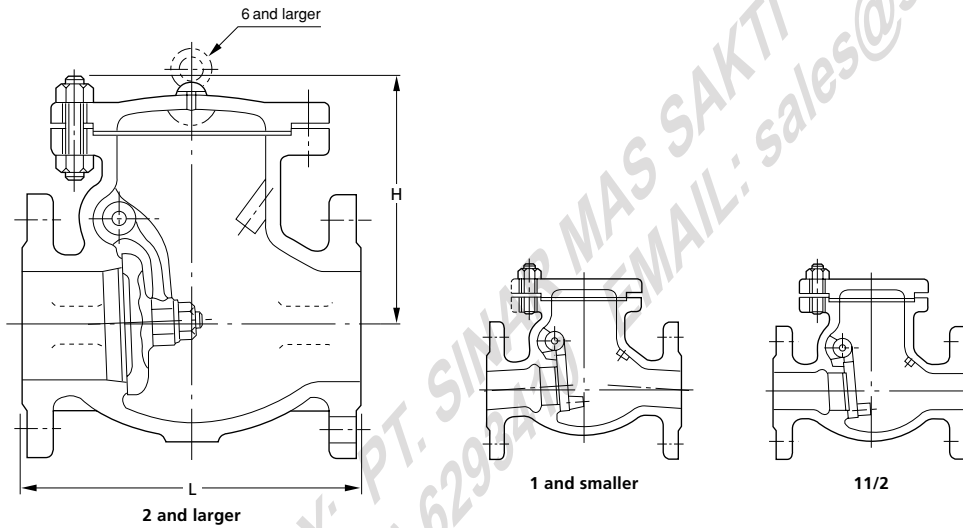

**Materials**

Parts	150UOC	150UOCM
Body*	CF8	CF8M
Cover	CF8	CF8M
Disc*	CF8	CF8M
Gasket	Refer to Page 10	
Disc nut**	304	316
Hinge pin	304	316
Plug	304	316
Arm**	CF8	CF8M
Washer**	304	316, 316L (3-6)
Cover bolt/nut	B8/8	
Split pin**	304	316L
Name plate	Aluminum	

\*Body seats and/or disc seats can be optionally hard-faced.

\*\*For size 2 and larger.

Note: Renewable seats are optionally available for size 2 and larger.

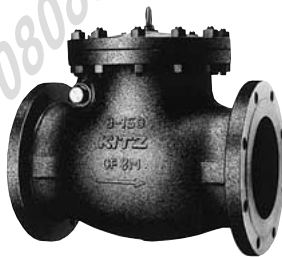

Items	
Face-to-Face Dimensions	ASME B16.10
End Flange Dimensions	ASME B16.5
Wall Thickness	API 600 Class150

Nominal Size	1/2	3/4	1	1 1/2	2	2 1/2	3	4	6	8	10	12	14	16	18	20	24	
		15	20	25	40	50	65	80	100	150	200	250	300	350	400	450	500	600
L	in.	4.25	4.62	5.00	6.50	8.00	8.50	9.50	11.50	14.00	19.50	24.50	27.50	31.00	34.00	38.50	38.50	51.00
	mm	108	117	127	165	203	216	241	292	356	495	622	698	787	864	978	978	1295
H	in.	3.2	3.3	3.9	4.5	6.0	6.7	7.1	7.9	9.8	11.0	13.4	14.8	15.7	16.9	18.3	19.7	22.8
	mm	80	84	100	115	152	170	180	200	250	280	340	376	398	428	465	500	580

**Class 300**

**SWING CHECK VALVE**

Pressure-Temperature Rating: ASME B 16.34

300UOC

300UOCM

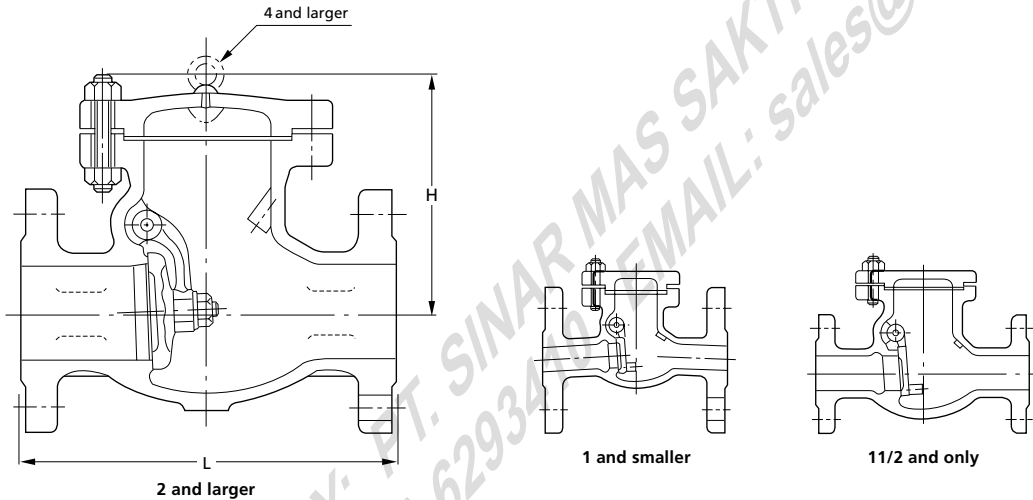

**Materials**

Parts	150UPC	150UPCM
Body*	CF8	CF8M
Cover	CF8	CF8M
Disc*	CF8	CF8M
Gasket	Refer to Page 6	
Disc nut**	304	316
Hinge pin	304	316
Plug	304	316
Arm**	CF8	CF8M
Washer**	304	316, 316L (3-6)
Cover bolt/nut	B8/8	
Split pin**	304	316L
Name plate	Aluminum	

\*Body seats and/or disc seats can be optionally hard-faced.

\*\*For size 2 and larger.

Note : Renewable seats are optionally available for size 2 and larger.



Items	
Face-to-Face Dimensions	ASME B16.10
End Flange Dimensions	ASME B16.5
Wall Thickness	API 600 Class300

Nominal Size	1/2	3/4	1	1 1/2	2	2 1/2	3	4	6	8	10	12	14	16	18	20	24	
	15	20	25	40	50	65	80	100	150	200	250	300	350	400	450	500	600	
<b>L</b>	in.	5.50	6.00	8.50	9.50	10.50	11.50	12.50	14.00	17.50	21.00	24.50	28.00	33.00	34.00	38.50	40.00	53.00
	mm	140	152	216	241	267	292	318	356	444	533	622	711	838	864	978	1016	1346
<b>H</b>	in.	3.2	3.3	4.0	4.6	60.5	7.5	8.1	8.9	10.7	13.0	14.2	16.0	18.9	20.7	21.9	24.3	28.8
	mm	81	84	101	118	165	190	205	225	272	330	360	406	480	527	555	618	732

**Class 600**

**SWING CHECK VALVE**

Pressure-Temperature Rating: ASME B 16.34

600UOC

600UOCM

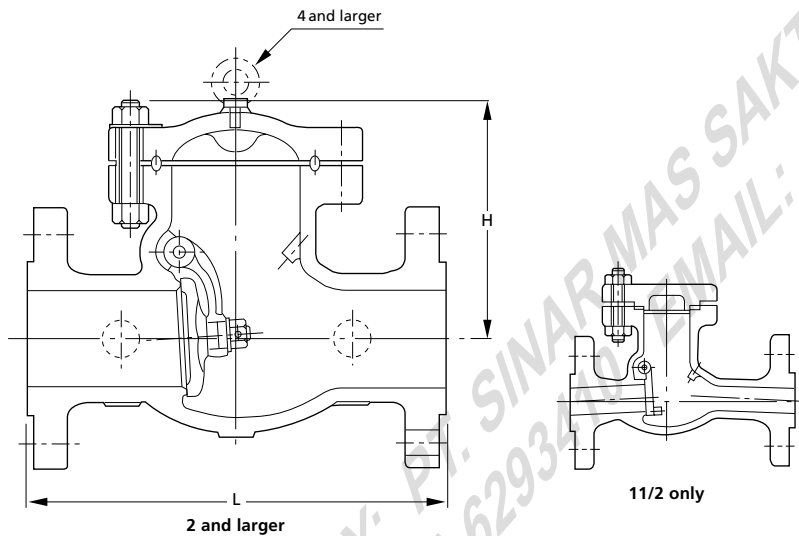

**Materials**

Parts	600UOC	600UOCM
Body*	CF8	CF8M
Cover	CF8	CF8M
Disc*	CF8	CF8M
Disc nut**	304	316
Gasket	Refer to Page 10	
Hinge pin**	304	316
ArmH2	CF8	CF8M
Cover bolt/nut	B8/8	
Eye bolt	Carbon steel	
Plug	304	316
Name plate	Aluminum	

\*Body seats and/or disc seats can be optionally hard-faced.

\*\*For size 2 and larger.

Note: Renewable seats are optionally available for size 2 and larger.



Items	
Face-to-Face Dimensions	ASME B16.10
End Flange Dimensions	ASME B16.5
Wall Thickness	API 600 Class600

Nominal Size	1		1 1/2		2		3		4		6		8		10		12		
	in.	mm	in.	mm	in.	mm	in.	mm	in.	mm	in.	mm	in.	mm	in.	mm	in.	mm	
L	in.	8.50	9.50	11.50	14.00	17.00	22.00	26.00	31.00	33.00									
	mm	216	241	292	356	432	559	660	787	838									
H	in.	5.6	6.8	6.8	8.7	10.1	12.4	14.1	16.3	18.2									
	mm	142	172	172	220	256	316	358	415	462									

**Class 900**

**SWING CHECK VALVE**

Pressure-Temperature Rating: ASME B 16.34

900UOC

900UOCM

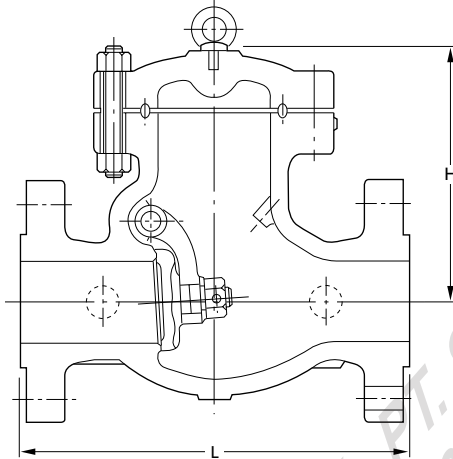

**Materials**

Parts	1500UOC	1500UOCM
Body*	CF8	CF8M
Cover	CF8	CF8M
Disc	CF8	CF8M
Disc nut	304	316
Gasket	Refer to Page 10	
Hinge pin	304	316
Arm	CF8	CF8M
Cover bolt/nut	B8/8	
Eye bolt	Carbon steel	
Plug	304	316
Name plate	304	

\*Body seats and/or disc seats can be optionally hard-faced.  
Note: All integral seats

Items	
Face-to-Face Dimensions	ASME B16.10
End Flange Dimensions	ASME B16.5
Wall Thickness	API 600 Class900

Nominal Size	3		4		6		8	
	in.	mm	in.	mm	in.	mm	in.	mm
L	in.	15.00	in.	18.00	in.	24.00	in.	29.00
	mm	381	mm	457	mm	610	mm	737
H	in.	11.5	in.	13.6	in.	17.5	in.	20.7
	mm	292	mm	346	mm	444	mm	526

**Class 1500**

**SWING CHECK VALVE**

Pressure-Temperature Rating: ASME B 16.34

1500UOC

1500UOCM

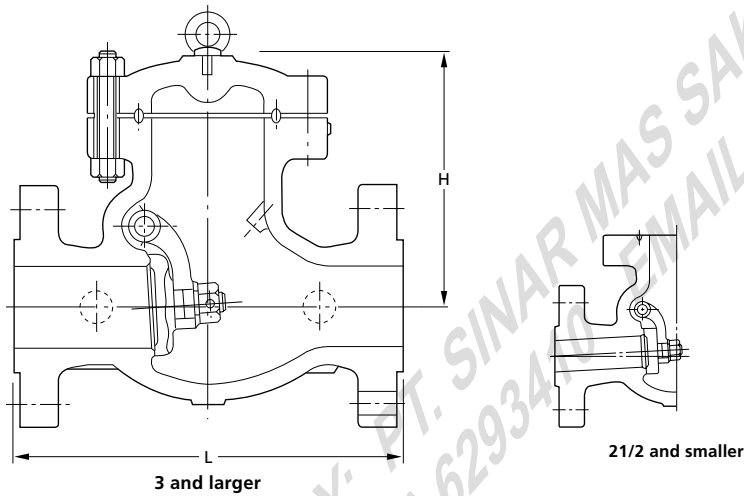

3 and larger

2 1/2 and smaller

**Materials**

Parts	1500UOC	1500UOCM
Body*	CF8	CF8M
Cover	CF8	CF8M
Disc*	CF8	CF8M
Disc nut	304	316
Gasket	Refer to Page 10	
Hinge pin	304	316
Arm	CF8	CF8M
Cover bolt/nut	B8/8	
Eye bolt	Carbon steel	
Plug	304	316
Name plate	304	

\*Body seats and/or disc seats can be optionally hard-faced.  
Note: All integral seats

Items	
Face-to-Face Dimensions	ASME B16.10
End Flange Dimensions	ASME B16.5
Wall Thickness	API 600 Class1500

Nominal Size	2	2 1/2	3	4	6	8
	50	65	80	100	150	200
<b>L</b>	14.50	16.50	18.50	21.50	27.75	32.75
	368	419	470	546	705	832
<b>H</b>	11.4	12.4	13.7	15.4	20.3	25.6
	290	316	347	391	515	650

PROVIDED BY: PT. SINAR MAS SAKTI  
 TEL: (62 21) 6008088 FAX: (62 21) 6293400 EMAIL: sales@smsakti.com

10K

GATE VALVE

Pressure-Temperature Rating: 1.0MPa: 180°C  
200psi. W.O.G.: 350°F S.P.

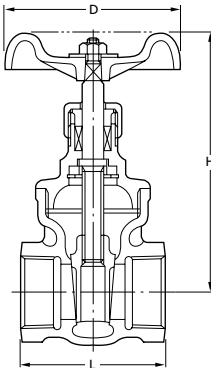

Parts	UEL	UELM
Body	SCS13A	SCS14A
Bonnet	SCS13A	SCS14A
Stem	SUS304	SUS316
Disc	SCS13A	SCS14A
Gland	SUS304	SUS316
Gland packing	Refer to Page 10	
Packing nut	SCS13A	
Handwheel	ZDC (1/2 & 3/4) / ADC12 (1-2)	
Name plate	A1050P	

Face-to-Face Dimensions: KITZ Std.  
End Thread Dimensions: JIS B0203  
Wall Thickness: KITZ Std.

Nominal Size	Unit:mm					
	1/2	3/4	1	1 1/4	1 1/2	2
L	54	58	65	74	78	87
H	96	101	112	123	150	167
D	70	70	80	80	100	100

UEL

UELM

10K

GATE VALVE

Pressure-Temperature Rating: 1.0MPa: 180°C  
200psi. W.O.G.: 350°F S.P.

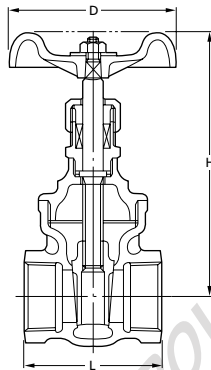

Parts	UE	UEM
Body	SCS13A	SCS14A
Bonnet	SCS13A	SCS14A
Stem	SUS304	SUS316
Disc	SCS13A	SCS14A
Gland	SUS304	SUS316
Gland packing	Refer to Page 10	
Packing nut	SCS13A	
Handwheel	ADC12 (2 1/2 & 3) / FDC400 (4)	
Name plate	A1050P	

Face-to-Face Dimensions: JIS B2011  
End Thread Dimensions: JIS B0203  
Wall Thickness: JIS B2011

Nominal Size	Unit:mm		
	2 1/2	3	4
L	115	130	155
H	248	275	315
D	135	155	200

UE

UEM

10K

GATE VALVE

Pressure-Temperature Rating: 1.0MPa: 180°C

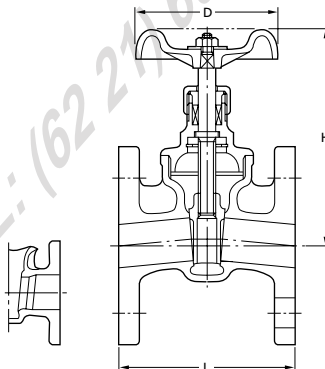

Parts	UEB	UEBM
Body	SCS13A	SCS14A
Bonnet	SUS304/SCS13A	SUS316/SCS14A
Stem	SUS304	SUS316
Disc	SCS13A	SCS14A
Gland	SUS304	SUS316
Gland packing	Refer to Page 10	
Packing nut	SCS13A/SUS304	
Handwheel	ZDC (1/2 & 3/4) / ADC12 (1-3)	
Snap ring	SUS316	
Name plate	A1050P	

Face-to-Face Dimensions: JIS B2011\*    \*KITZ standard for Size 1/2 & 3/4.  
End Flange Dimensions: JIS B2220\*\*    \*\*Except flange thickness.  
Wall Thickness: KITZ Std.

Nominal Size	Unit:mm							
	1/2*	3/4*	1	1 1/4	1 1/2	2	2 1/2	3
L	85	95	100	110	125	140	170	190
H	99	105	116	128	170	188	248	275
D	70	70	80	80	100	100	135	155

UEB

UEBM

\*UEB only

2 1/2 and larger

2 1/2 and smaller

**Class 200**

**GATE VALVE**

Pressure-Temperature Rating: 1.0MPa: 180°C  
200psi. W.O.G.: 350°F S.P.

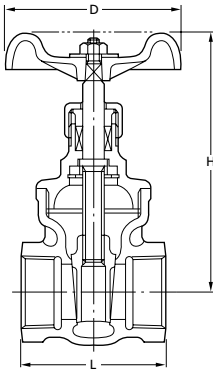

AKUELM



Parts	AKUELM
Body	CF8M
Bonnet	CF8M
Stem	316
Disc	CF8M
Gland	316
Gland packing	Refer to Page 10
Packing nut	CF8
Handwheel	ZDC (1/2 & 3/4) / ADC12 (1~2)
Name plate	A1050P

Face-to-Face Dimensions: KITZ Std.  
End Thread Dimensions: ASME B1.20.1  
Wall Thickness: KITZ Std.

Nominal Size	Unit:mm					
	1/2	3/4	1	1 1/4	1 1/2	2
L	54	58	65	74	78	87
H	96	101	112	123	150	167
D	70	70	80	80	100	100

**Class 200**

**GATE VALVE**

Pressure-Temperature Rating: 1.0MPa: 180°C  
200psi. W.O.G.: 350°F S.P.

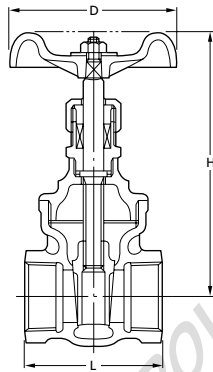

AKUEM



Parts	AKUEM
Body	CF8M
Bonnet	CF8M
Stem	316
Disc	CF8M
Gland	316
Gland packing	Refer to Page 10
Packing nut	CF8
Handwheel	ADC12 (2 1/2 & 3) / FDC400 (4)
Name plate	A1050P

Face-to-Face Dimensions: JIS B2011  
End Thread Dimensions: ASME B1.20.1  
Wall Thickness: KITZ Std.

Nominal Size	Unit:mm		
	2 1/2	3	4
L	115	130	155
H	248	275	315
D	135	155	200

**5K**

**GLOBE VALVE**

Pressure-Temperature Rating: 0.5MPa: 150°C

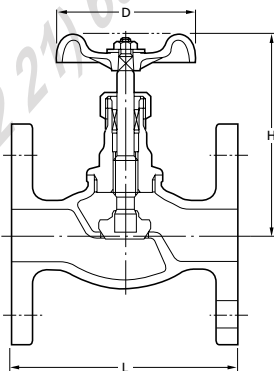

UAB



Parts	UAB
Body	SCS13A
Bonnet	SCS13A
Stem	SUS304
Disc	SUS304
Gland	SUS304
Gland packing	Refer to Page 10
Packing nut	SCS13A/SUS304
Handwheel	ZDC (3/8 - 3/4) / ADC12 (1~2)
Name plate	A1050P

Face-to-Face Dimensions: KITZ Std. \*Except flange thickness.  
End Flange Dimensions: JIS B2220\*  
Wall Thickness: KITZ Std.

Nominal Size	Unit:mm						
	3/8	1/2	3/4	1	1 1/4	1 1/2	2
L	73	85	95	108	120	135	155
H	106	106	108	119	142	155	186
D	70	70	70	80	90	90	115

5K

GLOBE VALVE

Pressure-Temperature Rating: 1.0MPa: 180°C  
200psi. W.O.G.: 350°F S.P.

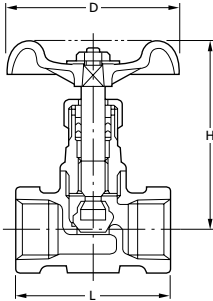

UCL



Parts	UCL
Body	SCS13A
Bonnet	SCS13A
Stem	SUS304
Disc	SUS304
Gland	SUS304
Gland packing	Refer to Page 10
Packing nut	SCS13A
Handwheel	ZDC (1/4- 1) / ADC (11/4-2)
Name plate	A1050P

Face-to-Face Dimensions: KITZ Std.  
End Thread Dimensions: JIS B0203  
Wall Thickness: KITZ Std.

Nominal Size	Unit:mm							
	1/4	3/8	1/2	3/4	1	1 1/4	1 1/2	2
L	44	48	52	60	72	80	90	100
H	68	68	68	93	100	122	138	153
D	55	55	55	60	70	80	90	100

10K

GLOBE VALVE

Pressure-Temperature Rating: 1.0MPa: 180°C  
200psi. W.O.G.: 350°F S.P.

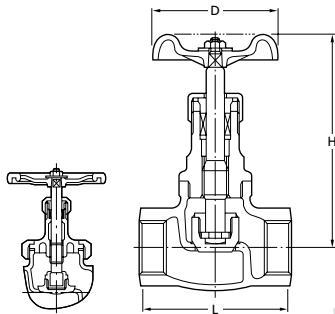

2 1/2 and larger

2 and smaller



Parts	UJ	UJM
Body	SCS13A	SCS14A
Bonnet	SCS13A	SCS14A
Stem	SUS304	SUS316
Disc	SUS304/SCS13A	SUS316/SCS14A
Gland	SUS304	SUS316
Lock nut	SUS304	SUS316
Gland packing	Refer to Page 10	
Packing nut	SCS13A/SUS304	
Handwheel	ZDC (3/8-3/4)	ADC12 (1-2)
Bonnet ring*	SCS13A	SCS14A
Gasket*	Asbestos-free sheet	
Packing washer	SUS316	
Stem washer	SUS316	
Name plate	A1050P	

\*For size 2 1/2 and larger. Note: Size 2 1/2 and larger for Fig. UJ / UJM.

	UJ	UJM
Face-to-Face Dimensions:	JIS B2011, KITZ Std.	
End Thread Dimensions:	JIS B0203	
Wall Thickness:	KITZ Std.	

Nominal Size	Unit:mm								
	3/8	1/2	3/4	1	1 1/4	1 1/2	2	2 1/2	3
L	55	65	80	90	105	120	140	180	200
H	109	111	112	142	150	171	189	253	280
D	60	60	70	90	90	100	115	180	225

10K

GLOBE VALVE

Pressure-Temperature Rating: 1.0MPa: 180°C

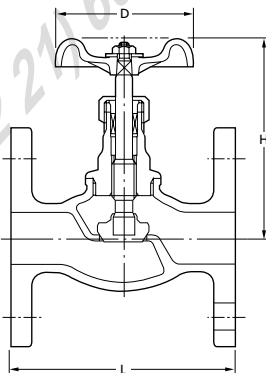

UCB



Parts	UCB
Body	SCS13A
Bonnet	SCS13A
Stem	SUS304
Disc	SUS304
Gland	SUS304
Gland packing	Refer to Page 10
Packing nut	SCS13A/SUS304
Handwheel	ZDC (3/8-3/4) / ADC12 (1-2)
Name plate	A1050P

Face-to-Face Dimensions: KITZ Std. \*Except flange thickness.  
End Flange Dimensions: JIS B2220\*  
Wall Thickness: KITZ Std.

Nominal Size	Unit:mm						
	3/8	1/2	3/4	1	1 1/4	1 1/2	2
L	73	85	95	108	120	135	155
H	106	106	108	119	142	155	186
D	70	70	70	80	90	90	115

10K

GLOBE VALVE

Pressure-Temperature Rating: 1.0MPa: 180°C  
200psi. W.O.G.: 350°F S.P.

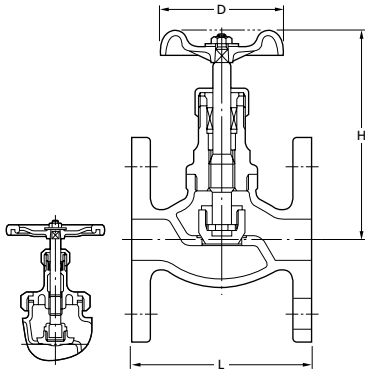

2 1/2 and larger      2 and smaller

UJB

UJBM



Face-to-Face Dimensions: JIS B2011  
End Flange Dimensions: JIS B2220\*  
Wall Thickness: KITZ Std.

\*Except flange thickness.

Parts	UJB	UJBM
Body	SCS13A	SCS14A
Bonnet	SCS13A	SCS14A
Stem	SUS304	SUS316
Disc	SUS304	SUS316/SCS14A
Gland	SUS304	SUS316
Gland packing	Refer to Page 10	
Packing nut	SUS304 / SCS13A	
Handwheel	ZDC (3/8-3/4) / ADC12 (1-2) / FCD400 (21/2&3)	
Bonnet ring*	SCS13A	SCS14A
Gasket*	Asbestos-free	
Packing washer	SUS316	
Stem washer	SUS316	
Name plate	A1050P	

\*For size 2 1/2 and larger

Nominal Size	Unit:mm								
	3/8	1/2	3/4	1	1 1/4	1 1/2	2	2 1/2	3
L	85	85	95	110	130	150	180	210	240
H	109	111	112	142	150	171	189	253	280
D	60	60	70	90	90	100	115	180	225

Class 200

GLOBE VALVE

Pressure-Temperature Rating: 1.0MPa: 180°C  
200psi. W.O.G.: 350°F S.P.

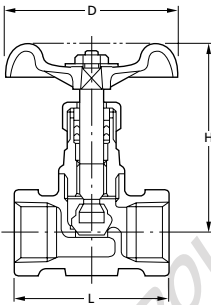

AKUCLM



Face-to-Face Dimensions: KITZ Std.  
End Thread Dimensions: ASME B1.20.1  
Wall Thickness: KITZ Std.

Parts	AKUCLM
Body	CF8M
Bonnet	CF8M
Stem	316
Disc	316
Gland	316
Gland packing	Refer to Page 10
Packing nut	CF8
Handwheel	ZDC (1/4- 1) / ADC (11/4-2)
Name plate	A1050P

Nominal Size	Unit:mm							
	1/4	3/8	1/2	3/4	1	1 1/4	1 1/2	2
L	44	48	52	60	72	80	90	100
H	68	68	68	93	100	122	138	153
D	55	55	55	60	70	80	90	100

Class 200

GLOBE VALVE

Pressure-Temperature Rating: 1.0MPa: 180°C  
200psi. W.O.G.: 350°F S.P.

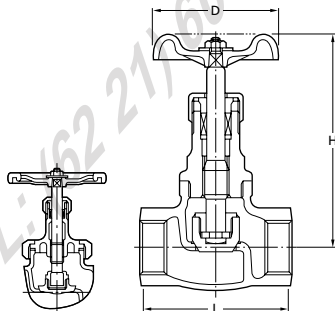

2 1/2 and larger      2 and smaller

AKUJM



Face-to-Face Dimensions: KITZ Std.  
End Thread Dimensions: ASME B1.20.1  
Wall Thickness: KITZ Std.

Parts	AKUJM
Body	CF8M
Bonnet	CF8M
Stem	316
Disc	316
Gland	316
Lock nut	316
Gland packing	Refer to Page 10
Packing nut	304/CF8
Handwheel	ZDC (3/8-3/4) ADC12 (1-2)
Bonnet ring*	—
Gasket*	Asbestos-free sheet
Packing washer	316
Stem washer	316
Name plate	A1050P

\*For size 2 1/2 and larger. Note: Size 2 1/2 and larger for Fig. UJ / UJM.

Nominal Size	Unit:mm								
	3/8	1/2	3/4	1	1 1/4	1 1/2	2	2 1/2	3
L	55	65	80	90	105	120	140	180	200
H	109	111	112	142	150	171	189	253	280
D	60	60	70	90	90	100	115	180	225

10K

GLOBE VALVE with PTFE DISC

Pressure-Temperature Rating: 1.0MPa: 180°C

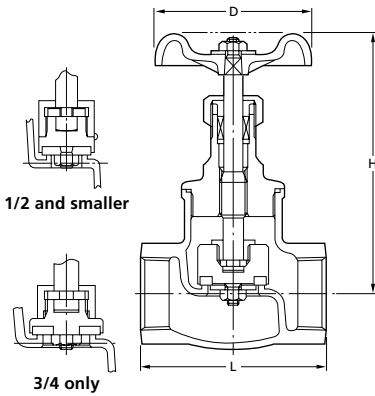

Face-to-Face Dimensions: JIS B2011  
End Thread Dimensions: JIS B0203  
Wall Thickness: KITZ Std.

Parts	UD	UDM
Body	SCS13A	SCS14A
Bonnet	SCS13A	SCS14A
Stem	SUS304	SUS316
Disc	PTFE	
Disc holder	SUS304	SUS316
Lock nut	SUS304	SUS316
Gland	SUS304	SUS316
Gland packing	Refer to Page 10	
Packing nut	SCS13A / SUS304	
Handwheel	ZDC (3/8-3/4) / ADC12 (1-2)	
Gasket	PTFE	
Packing washer	SUS316	
Stem washer	SUS316	
Name plate	A1050P	

Nominal Size	Unit:mm						
	3/8	1/2	3/4	1	1 1/4	1 1/2	2
L	55	65	80	90	105	120	140
H	109	112	113	143	156	171	189
D	60	60	70	90	90	100	115

UD

UDM

10K

GLOBE VALVE with PTFE DISC

Pressure-Temperature Rating: 1.0MPa: 180°C

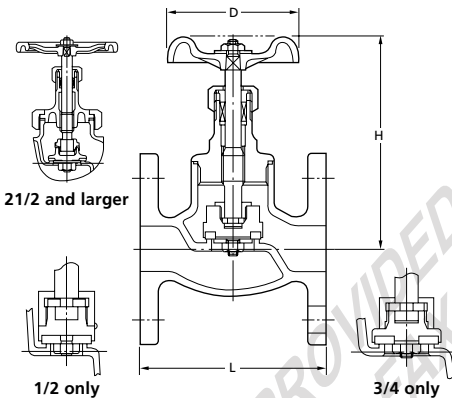

Face-to-Face Dimensions: JIS B2011  
End Flange Dimensions: JIS B2220\*  
Wall Thickness: KITZ Std.

\*Except flange thickness.

Parts	UJB	UJBM
Body	SCS13A	SCS14A
Bonnet	SCS13A	SCS14A
Stem	SUS304	SUS316
Disc	PTFE	
Disc holder	SUS304	SUS316
Lock nut	SUS304	SUS316
Gland	SUS304	SUS316
Gland packing	Refer to Page 10	
Packing nut	SCS13A / SCS13A	
Handwheel	ZDC (1/2&3/4) / ADC12 (1-2) / FCD400 (21/2&3)	
Bonnet ring*	SCS13A	SCS14A
Gasket*	PTFE	
Packing washer	SUS316	
Stem washer	SUS316	
Name plate	A1050P	

\*For size 2 1/2 and larger

Nominal Size	Unit:mm							
	1/2	3/4	1	1 1/4	1 1/2	2	2 1/2	3
L	85	95	110	130	150	180	210	240
H	112	113	143	150	171	189	252	277
D	60	70	90	90	100	115	180	225

UDB

UJBM

10K

SWING CHECK VALVE

Pressure-Temperature Rating: 1.0MPa: 180°C  
200psi. W.O.G.: 350°F S.P.

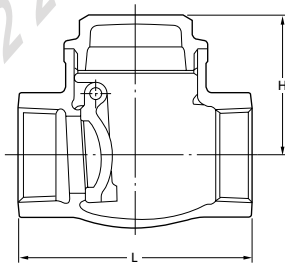

Face-to-Face Dimensions: JIS B2011\*  
End Thread Dimensions: ASME B1.20.1  
Wall Thickness: KITZ Std.

\*KITZ standard for Size 2 1/2 & 3

Parts	UO	UOM
Body	SCS13A	SCS14A
Cap	SCS13A/SUS304	SCS14A/SUS316
Disc	SCS13A	SCS14A
Hinge pin	SUS304	SUS316
Plug	SUS304	SUS316
Gasket (for plug)	Asbestos-free sheet	

Nominal Size	Unit:mm							
	1/2	3/4	1	1 1/4	1 1/2	2	2 1/2	3
L	65	80	90	105	120	140	180	200
H	45	55	61	71	72	81	93	104

UO

UOM

10K

SWING CHECK VALVE

Pressure-Temperature Rating: 1.0MPa: 180°C

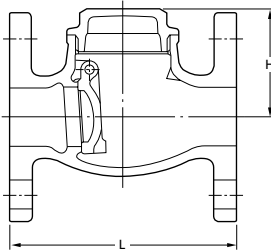

Parts	UOB	UOBM
Body	SCS13A	SCS14A
Cap	SCS13A/SUS304	SCS14A/SUS316
Disc	SCS13A	SCS14A
Hinge pin	SUS304	SUS316
Plug	SUS304	SUS316
Gasket (for plug)	Asbestos-free sheet	

Face-to-Face Dimensions: JIS B2011 \*Except flange thickness.  
 End Flange Dimensions: JIS B2220\*  
 Wall Thickness: KITZ Std.

UOB

UOBM

Nominal Size	Unit:mm							
	1/2	3/4	1	1 1/4	1 1/2	2	2 1/2	3
L	15	20	25	32	40	50	65	80
H	45	55	61	71	72	81	95	105

TYPE 200

SWING CHECK VALVE

Pressure-Temperature Rating: 1.0MPa: 180°C  
 200psi. W.O.G.: 350°F S.P.

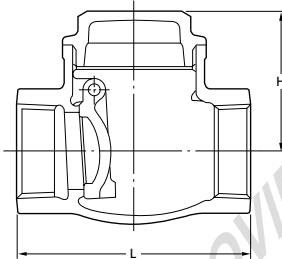

Parts	AKUOM
Body	CF8M
Cap	CF8M/316
Disc	CF8M
Hinge pin	316
Plug	316
Gasket (for plug)	Aramid fiber

Face-to-Face Dimensions: KITZ Std.  
 End Thread Dimensions: ASME B1.20.1  
 Wall Thickness: KITZ Std.

AKUOM

Nominal Size	Unit:mm							
	1/2	3/4	1	1 1/4	1 1/2	2	2 1/2	3
L	65	80	90	105	120	140	180	200
H	45	55	61	71	72	81	93	104

10K

LIFT CHECK VALVE

Pressure-Temperature Rating: 1.0MPa: 180°C

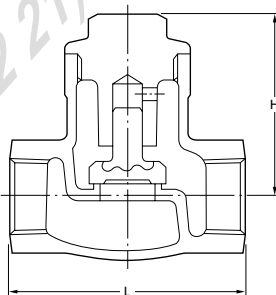

Parts	UN
Body	SCS13A
Cap	SCS13A/SUS304
Disc	SUS304

Face-to-Face Dimensions: JIS B2011  
 End Thread Dimensions: JIS B0203  
 Wall Thickness: KITZ Std.

UN

Nominal Size	Unit:mm						
	3/8	1/2	3/4	1	1 1/4	1 1/2	2
L	10	15	20	25	32	40	50
H	55	65	80	90	105	120	140

10K

Y-PATTERN STRAINER

Pressure-Temperature Rating: 1.0MPa: 180°C

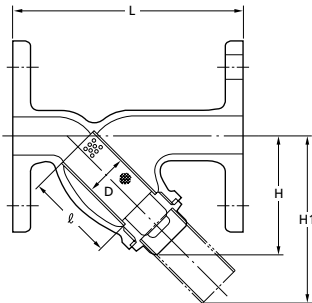

Parts	UYB	UYBM
Body	SCS13A	SCS14A
Cover	SCS13A/SUS304	SCS14A/SUS316
Gasket	Ceramic filled PTFE	
Screen	SUS304	SUS316

Face-to-Face Dimensions: KITZ Std. \*Except flange thickness.  
 End Flange Dimensions: JIS B2220\*  
 Wall Thickness: KITZ Std.

UYB UYBM

Nominal Size	3/8	1/2	3/4	1	1 1/4	1 1/2	2	Unit:mm
L	110	120	130	150	170	190	220	
H	50	58	66	78	93	104	122	
H1	67	80	91	109	132	145	174	
D	15	18	23	30	39	46	58	
l	36	43	48	58	69	75	90	

20K

Y-PATTERN STRAINER

Pressure-Temperature Rating: 2.0MPa: 180°C

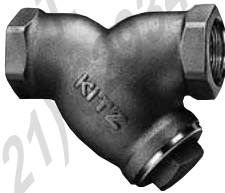
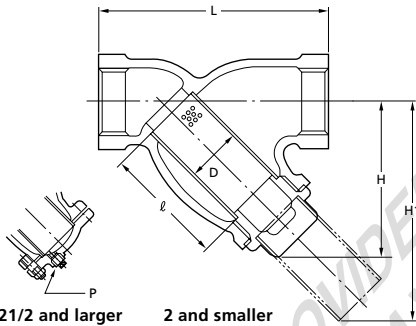

Parts	UY	UYM
Body	SCS13A	SCS14A
Cover	SUS304/SCS13A	SUS316/SCS14A
Gasket	Ceramic filled PTFE	
Screen	SUS304	SUS316
Cover bolt/nut*	SUS304/304	
Plug*	SUS304	SUS316

\*For size 2 1/2" and larger.  
 Note: Screen is a 40-mesh stainless wire net reinforced with SUS304/316.

Face-to-Face Dimensions: KITZ Std.  
 End Thread Dimensions: JIS B0203  
 Wall Thickness: KITZ Std.

UY UYM

Nominal Size	1/4	3/8	1/2	3/4	1	1 1/4	1 1/2	2	2 1/2	3	Unit:mm
L	65	70	85	100	115	135	150	180	220	250	
H	50	50	60	65	77	90	100	115	150	193	
H1	67	68	80	90	107	128	140	165	215	267	
D	15	15	18	23	30	39	46	58	72	86	
l	36	36	43	48	58	69	75	90	120	150	
P	—	—	—	—	—	—	—	—	Rc1/2	Rc1/2	

**CLASS 150**

**GATE VALVE**

Pressure-Temperature Rating: ASME B16.34

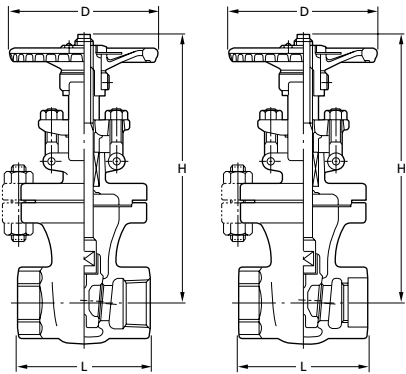

**AK150UMM**

• Threaded ends

**AW150UMM**

• Socket Welding Ends



Parts	Material	Parts	Material
Body	CF3M	Handwheel	Ductile iron
Bonnet	CF8M	Gasket	Refer to Page 6
Stem	316	Bonnet bolt/nut	B8/8
Disc	CF8M	Gland bolt/nut	B8/8
Gland	316	Yoke sleeve	Ductile Ni-resist
Gland packing	Refer to Page 10	Name plate	Aluminum
Gland flange	CF8		

End to end: KITZ Std.  
 Connecting Threads: ASME B1.20.1  
 Connecting Sockets: ASME B16.11  
 Wall Thickness: ASME B16.34 Class150

Nominal Size	AK150UMM					AW150UMM				
	1/2	3/4	1	1 1/2	2	1/2	3/4	1	1 1/2	2
L	in. 2.75	3.0	3.5	4.5	5.0	15	20	25	40	50
	mm 70	76	89	114	121	67	73	86	111	118
H (open)	in. 7.7	8.03	8.7	10.87	13.2	7.7	8.03	8.7	10.87	13.2
	mm 195	204	220	276	336	195	204	220	276	336
D	in. 3.5	3.5	3.9	5.5	6.3	3.5	3.5	3.9	5.5	6.3
	mm 90	90	100	140	160	90	90	100	140	160

**CLASS 300**

**GATE VALVE**

Pressure-Temperature Rating: ASME B16.34

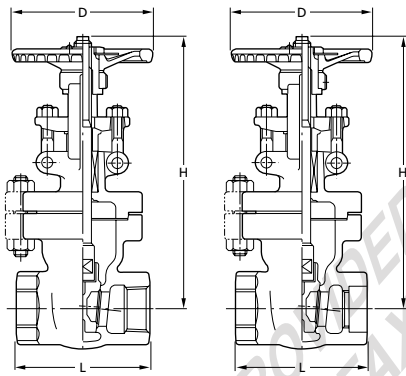

**AK300UMM**

• Threaded ends

**AW300UMM**

• Socket Welding Ends



Parts	Material	Parts	Material
Body	CF3M	Handwheel	Ductile iron
Bonnet	CF8M	Gasket	Refer to Page 6
Stem	316	Bonnet bolt/nut	B8/8
Disc	CF8M	Gland bolt/nut	B8/8
Gland	316	Yoke sleeve	Ductile Ni-resist
Gland packing	Refer to Page 10	Name plate	Aluminum
Gland flange	CF8		

Note: Flexible wedge for all sizes.

End to end: KITZ Std.  
 Connecting Threads: ASME B1.20.1  
 Connecting Sockets: ASME B16.11  
 Wall Thickness: ASME B16.34 Class300

Nominal Size	AK300UMM					AW300UMM				
	1/2	3/4	1	1 1/2	2	1/2	3/4	1	1 1/2	2
L	in. 3.0	3.25	3.75	5.0	5.75	2.87	3.15	3.62	4.88	5.63
	mm 76	83	95	127	146	73	80	92	124	143
H (open)	in. 7.95	8.3	9.1	11.2	13.5	8.0	8.3	9.1	11.2	13.5
	mm 202	212	230	285	344	202	212	230	285	344
D	in. 3.9	3.9	3.9	5.5	7.1	3.9	3.9	3.9	5.5	7.1
	mm 100	100	100	140	180	100	100	100	140	180

**CLASS 600**

**GATE VALVE**

Pressure-Temperature Rating: ASME B16.34

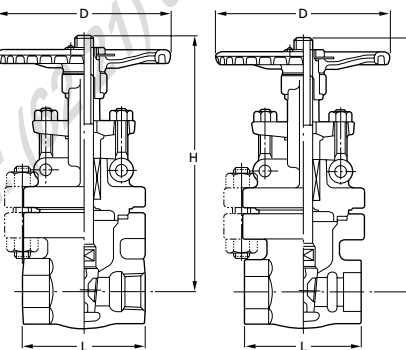

**AK600UMM**

• Threaded ends

**AW600UMM**

• Socket Welding Ends



Parts	Material	Parts	Material
Body	CF3M	Handwheel	Ductile iron
Bonnet	CF8M	Gasket	Refer to Page 6
Stem	316	Bonnet bolt/nut	B8/8
Disc	CF8M	Gland bolt/nut	B8/8
Gland	316	Yoke sleeve	Ductile Ni-resist
Gland packing	Refer to Page 10	Name plate	Aluminum
Gland flange	CF8		

Note: Flexible wedge for all sizes.

End to end: KITZ Std.  
 Connecting Threads: ASME B1.20.1  
 Connecting Sockets: ASME B16.11  
 Wall Thickness: ASME B16.34 Class600

Nominal Size	AK600UMM					AW600UMM				
	1/2	3/4	1	1 1/2	2	1/2	3/4	1	1 1/2	2
L	in. 3.0	3.25	3.75	5.0	5.75	2.87	3.15	3.62	4.88	5.63
	mm 76	83	95	127	146	73	80	92	124	143
H (open)	in. 7.99	8.46	9.5	12.8	15.2	7.9	8.46	9.5	12.8	15.2
	mm 201	215	240	325	385	201	215	240	325	385
D	in. 3.9	3.9	5.5	7.1	7.9	3.9	3.9	5.5	7.1	7.9
	mm 100	100	140	180	200	100	100	140	180	200

**CLASS 150** **GLOBE VALVE**

Pressure-Temperature Rating: ASME B16.34

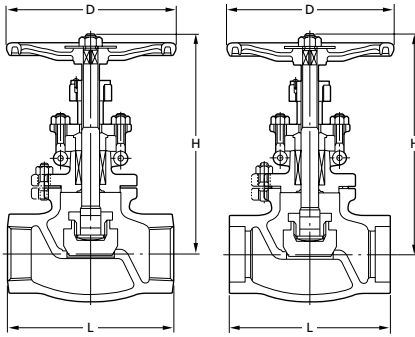

**AK150UPM**

• Threaded ends

**AW150UPM**

• Socket Welding Ends



Parts	Material	Parts	Material
Body	CF3M	Handwheel	Ductile iron
Bonnet	CF8M	Gasket	Refer to Page 6
Stem	316	Gland flange	CF8
Disc	316	Bonnet bolt/nut	B8/8
Lock nut	316	Gland bolt/nut	B8/8
Gland	316	Yoke bush	Ductile Ni-resist
Gland packing	Refer to Page 10	Name plate	Aluminum

End Flange Dimensions: KITZ Std.  
 Connecting Threads: ASME B1.20.1  
 Connecting Sockets: ASME B16.11  
 Wall Thickness: ASME B16.34 Class150

Nominal Size	AK150UPM					AW150UPM				
	1/2	3/4	1	1 1/2	2	1/2	3/4	1	1 1/2	2
L	in. 3.4	3.75	4.25	5.5	6.5	in. 3.3	3.6	4.1	5.4	6.4
	mm 86	95	108	140	165	mm 83	92	105	137	162
H (open)	in. 6.5	6.5	6.71	7.8	9.1	in. 6.5	6.5	6.7	7.8	9.1
	mm 164	166	69	198	230	mm 164	166	169	198	230
D	in. 3.5	3.5	3.9	5.5	6.3	in. 3.5	3.5	3.9	5.5	6.3
	mm 90	90	100	140	160	mm 90	90	100	140	160

**CLASS 300** **GLOBE VALVE**

Pressure-Temperature Rating: ASME B16.34

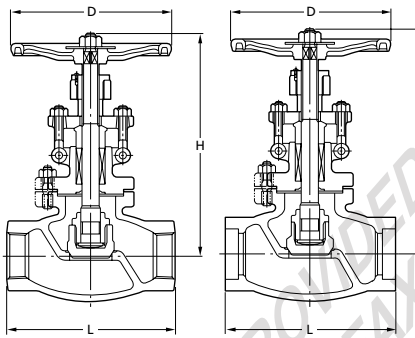

**AK300UPM**

• Threaded ends

**AW300UPM**

• Socket Welding Ends



Parts	Material	Parts	Material
Body	CF3M	Gland flange	CF8
Bonnet	CF8M	Handwheel	Ductile iron
Stem	316	Gasket	Refer to Page 6
Disc	316/CF8M	Bonnet bolt/nut	B8/8
Lock nut	316	Gland bolt/nut	B8/8
Gland	316	Yoke bush	Ductile Ni-resist
Gland packing	Refer to Page 10	Name plate	Aluminum

End Flange Dimensions: KITZ Std.  
 Connecting Threads: ASME B1.20.1  
 Connecting Sockets: ASME B16.11  
 Wall Thickness: ASME B16.34 Class300

Nominal Size	AK300UPM					AW300UPM				
	1/2	3/4	1	1 1/2	2	1/2	3/4	1	1 1/2	2
L	in. 3.75	4.25	5.0	6.5	7.58	in. 3.62	4.13	4.88	6.37	7.36
	mm 95	108	127	165	190	mm 92	105	124	162	187
H (open)	in. 7.0	7.1	7.2	9.2	11.4	in. 7.0	7.1	7.2	9.2	11.3
	mm 178	180	184	233	289	mm 178	180	184	233	289
D	in. 3.9	3.9	3.9	6.3	7.1	in. 3.9	3.9	3.9	6.3	7.1
	mm 100	100	100	160	180	mm 100	100	100	160	180

Unit:mm

**Welding Dimensions Required for Socket Welding Vales**

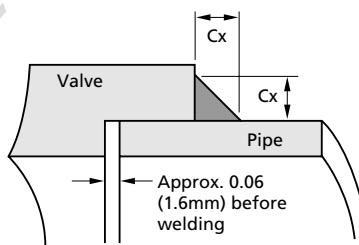

**Minimum Leg of Fillet Weld. Cx**

Unit: inches (mm)

Sch. No.	1/2	3/4	1	1 1/2	2
5S/10S	0.125 (3.2)				
40			0.145 (3.7)	0.159 (4.0)	0.168 (4.3)
80	0.161 (4.0)	0.168 (4.3)	0.196 (5.0)	0.218 (5.6)	0.238 (6.1)
160	0.205 (5.3)	0.239 (6.1)	0.273 (7.0)	0.307 (7.8)	0.375 (9.6)

**CLASS 150 SWING CHECK VALVE**

Pressure-Temperature Rating: ASME B16.34

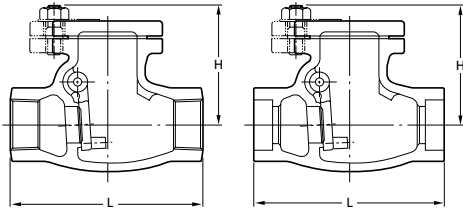

Parts	Material	Parts	Material
Body	CF3M	Plug	316
Cover	CF8M	Gasket	Refer to Page 6
Disc	CF8M	Cover bolt/nut	B8/8
Hinge pin	316	Name plate	Aluminum

End to end: KITZ Std.  
 Connecting Threads: ASME B1.20.1  
 Connecting Sockets: ASME B16.11  
 Wall Thickness: ASME B16.34 Class150

Unit:mm

**AK150UOM**  
 • Threaded ends

**AW150UOM**  
 • Socket Welding Ends

Nominal Size	AK150UOM					AW150UOM				
	1/2	3/4	1	1 1/2	2	1/2	3/4	1	1 1/2	2
	15	20	25	40	50	15	20	25	40	50
L	3.75	3.75	5.0	6.0	6.5	3.6	3.6	4.9	5.9	6.4
	95	95	127	152	165	92	92	124	149	162
H	2.8	3.0	3.2	4.1	4.7	2.8	3.0	3.2	4.1	4.7
	70	75	81	104	120	70	75	81	104	120

**CLASS 300 SWING CHECK VALVE**

Pressure-Temperature Rating: ASME B16.34

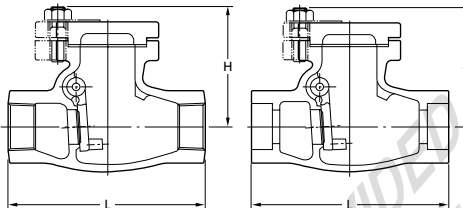

Parts	Material	Parts	Material
Body	CF3M	Plug	316
Cover	CF8M	Gasket	Refer to Page 6
Disc	CF8M	Cover bolt/nut	B8/8
Hinge pin	316	Name plate	Aluminum

End to end: KITZ Std.  
 Connecting Threads: ASME B1.20.1  
 Connecting Sockets: ASME B16.11  
 Wall Thickness: ASME B16.34 Class300

Unit:mm

**AK300UOM**  
 • Threaded ends

**AW300UOM**  
 • Socket Welding Ends

Nominal Size	AK300UOM					AW300UOM				
	1/2	3/4	1	1 1/2	2	1/2	3/4	1	1 1/2	2
	15	20	25	40	50	15	20	25	40	50
L	4.5	5.0	5.5	6.0	6.5	4.37	4.88	5.39	5.86	6.37
	114	127	140	152	165	111	124	137	149	162
H	3.1	3.2	3.7	4.5	5.3	3.1	3.2	3.7	4.5	5.3
	78	80	9.3	114	135	78	82	93	114	135

**Cautionary Note Regarding Installation of Socket welding Joints**

To prevent problems in the cracking of the fillet welds when the pipe is seated against the bottom of the socket prior to welding, it is recommended that the pipe be withdrawn approximately 0.06 in (1.6 mm) away from contact with the bottom of the socket before starting the weld.

Valves should be welded with the disc slightly opened, using weld material (rod or wire) with an appropriate diameter to meet the dimension and shape of the area to be welded, for prevention of overheating valves.

**CLASS 150**

**FULL JACKETED GATE VALVE**

Pressure-Temperature Rating: ASME B 16.34

150UMAJ

150UMAJM

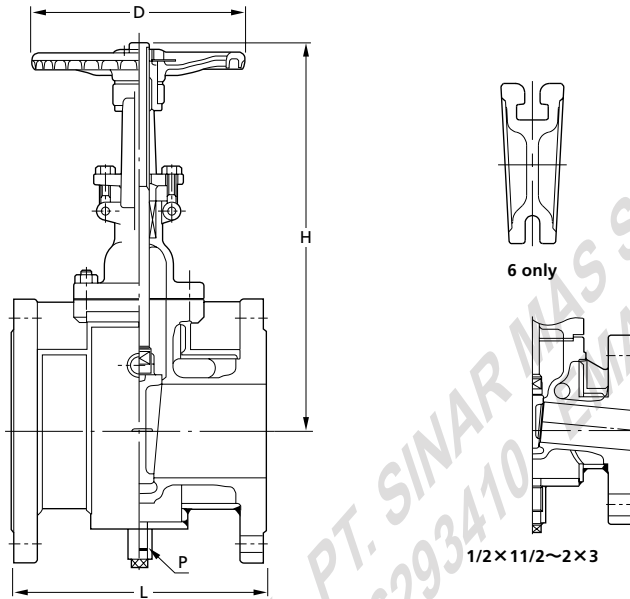

**Materials**

Parts	150UMAJ	150UMAJM
Body	CF8	CF8M
Bonnet	CF8	CF8M
Stem	304	316
Disc	CF8	CF8M
Gland	304	316
Gland flange	CF8	
Gland packing	Refer to Page 10	
Gasket	Refer to Page 10	
Yoke sleeve	Ductile Ni-resist	
Handwheel	Ductile iron	
Gland bolt/nut	B8/8	
Gland bolt pin	403	
Bonnet bolt/nut	B8/8	
Name plate	Aluminum	
Jacket*	Carbon Steel+Steel	

\*The material may be changed depending on the service temperature.  
 Note: • Body seats and/or disc seats can be optionally hard-faced.  
 • Flexible wedge for all sizes.  
 • All flexible wedges

Items	
Face-to-Face Dimensions	KITZ Std.
End Flange Dimensions	ASME B16.5
Wall Thickness	ASME B16.34 Class 150

Nominal Size		1/2 x 1 1/2	3/4 x 1 1/2	1 x 2	1 1/2 x 2 1/2	2 x 3	3 x 4	4 x 6	6 x 8
		15 x 40	20 x 40	25 x 50	40 x 65	50 x 80	80 x 100	100 x 150	150 x 200
L	in.	6.50	6.50	7.00	7.40	8.00	9.00	10.50	11.50
	mm	165	165	177	187	203	229	267	292
H (open)	in.	7.8	8.4	9.1	11.1	12.7	17.6	20.6	28
	mm	199	213	232	283	322	447	523	710
D	in.	3.9	3.9	3.9	5.5	6.3	7.9	8.9	9.8
	mm	100	100	100	140	160	200	225	250
P		Rc 1/2	Rc 1/2	Rc 1/2	Rc 1/2	Rc 1/2	Rc 1/2	Rc 3/4	Rc 3/4

\*The nominal sizes are indicated by [the valve nominal sizes] and [flange nominal sizes].

**CLASS 300**

**FULL JACKETED GATE VALVE**

Pressure-Temperature Rating: ASME B 16.34

300UMAJ

300UMAJM

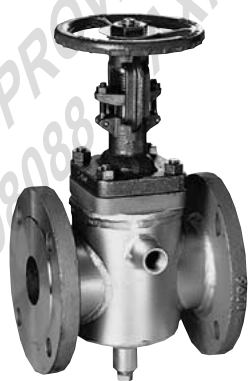
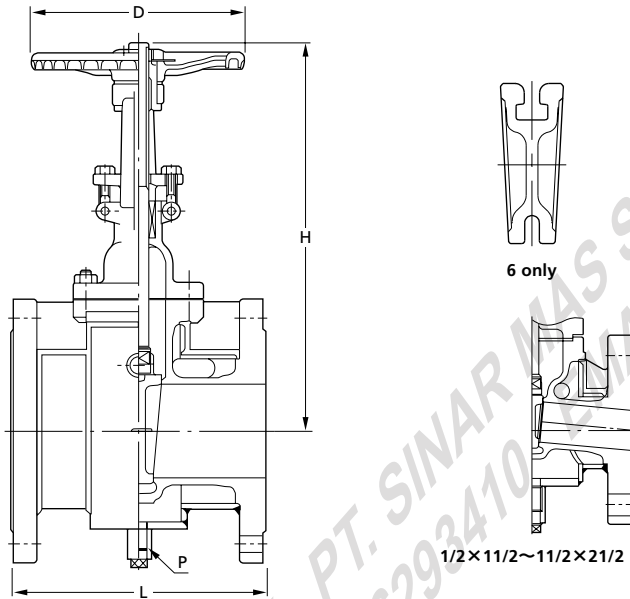

**Materials**

Parts	300UMAJ	300UMAJM
Body	CF8	CF8M
Bonnet	CF8	CF8M
Stem	304	316
Disc	CF8	CF8M
Gland	304	316
Gland flange	CF8	
Gland packing	Refer to Page 10	
Gasket	Refer to Page 10	
Yoke sleeve	Ductile Ni-resist	
Handwheel	Ductile iron	
Gland bolt/nut	304	B8/8
Gland bolt pin	403	
Bonnet bolt/nut	B8/8	
Name plate	Aluminum	
Jacket*	Carbon Steel+Steel	

\*The material may be changed depending on the service temperature.  
 Note: \* Body seats and/or disc seats can be optionally hard-faced.  
 \* Flexible wedge for all sizes.

Items	
Face-to-Face Dimensions	KITZ Std.
End Flange Dimensions	ASME B16.5
Wall Thickness	ASME B16.34 Class 300

Nominal Size		1/2x1 1/2	3/4x1 1/2	1x2	1 1/2x2 1/2	2x3	3x4	4x6	6x8
		15x40	20x40	25x50	40x65	50x80	80x100	100x150	150x200
L	in.	7.00	7.00	7.50	8.00	11.10	12.00	15.90	18.00
	mm	178	178	190	203	283	305	403	457
H (open)	in.	7.8	8.4	9.1	11.1	13.9	18.5	22	29.6
	mm	199	213	232	283	353	470	560	753
D	in.	3.9	3.9	3.9	5.5	7.1	8.9	9.8	13.8
	mm	100	100	100	140	180	225	250	350
P		Rc1/2	Rc1/2	Rc1/2	Rc1/2	Rc1/2	Rc1/2	Rc3/4	Rc3/4

\*The nominal sizes are indicated by [the valve nominal sizes] and [flange nominal sizes].

10K

FULL JACKETED GATE VALVE

Pressure-Temperature Rating: JIS B2220

10UMAJ

10UMAJM

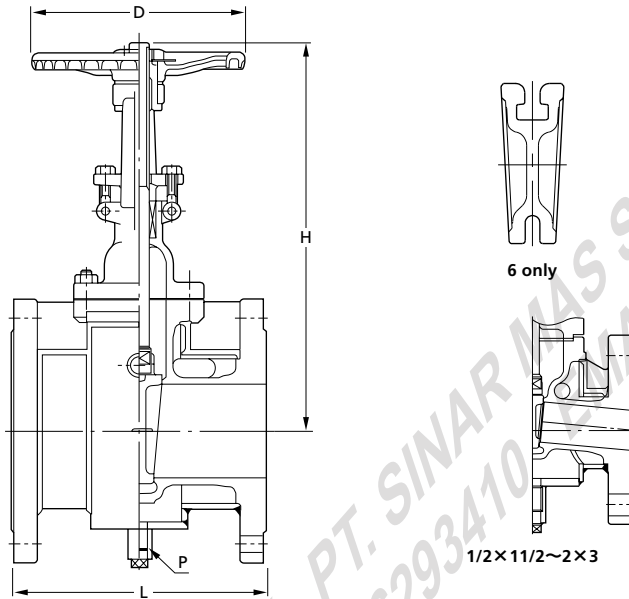

Materials

Parts	10UMAJ	10UMAJM
Body	SCS13A	SCS14A
Bonnet	SCS13A	SCS14A
Stem	SUS304	SUS316
Disc	SCS13A	SCS14A
Gland	SUS304	SUS316
Gland flange	SCS13A	
Gland packing	Refer to Page 10	
Gasket	Refer to Page 10	
Yoke sleeve	Ductile Ni-resist	
Handwheel	FCD400	
Gland bolt/nut	SUS304/304	
Gland bolt pin	SUS403	
Bonnet bolt/nut	SUS304/304	
Name plate	A1050P	
Jacket*	STPG370+SS400	

\*The material may be changed depending on the service temperature.  
 Note: \* Body seats and/or disc seats can be optionally hard-faced.  
 \* Flexible wedge for all sizes.  
 \* All flexible wedges

Items	
Face-to-Face Dimensions	KITZ Std.
End Flange Dimensions	JIS B2220
Wall Thickness	ASME B16.34 Class 150

Nominal Size	Unit:mm							
	1/2x1 1/2	3/4x1 1/2	1x2	1 1/2x2 1/2	2x3	3x4	4x6	6x8
L	15x40	20x40	25x50	40x65	50x80	80x100	100x150	150x200
H (open)	169	169	177	188	201	217	260	279
H	199	213	232	283	322	447	523	710
D	100	100	100	140	160	200	225	250
P	Rc1/2	Rc1/2	Rc1/2	Rc1/2	Rc1/2	Rc1/2	Rc3/4	Rc3/4

\*The nominal sizes are indicated by [the valve nominal sizes] and [flange nominal sizes].

20K

FULL JACKETED GATE VALVE

Pressure-Temperature Rating: JIS B2220

20UMAJ

20UMAJM

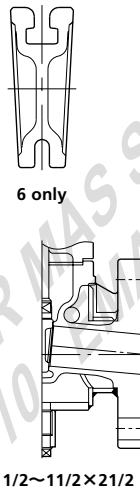
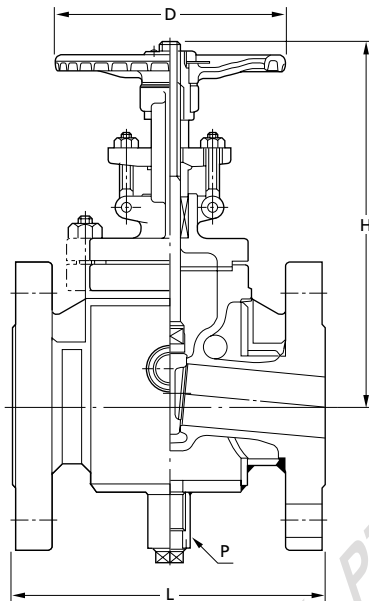

6 only



Materials

Parts	20UMAJ/20UMAJM
Body	SCS13A
Bonnet	SCS13A
Stem	SUS304
Disc	SCS13A
Gland	SUS304
Gland flange	SCS13A
Gland packing	Refer to Page 10
Gasket	Refer to Page 10
Yoke sleeve	Ductile Ni-resist
Handwheel	FCD400
Gland bolt/nut	SUS304/304
Gland bolt pin	SUS403
Bonnet bolt/nut	SUS304/304
Name plate	A1050P
Jacket*	STPG370+SS400

\*The material may be changed depending on the service temperature.  
 Note: \* Body seats and/or disc seats can be optionally hard-faced.  
 \* Flexible wedge for all sizes.

Items	
Face-to-Face Dimensions	KITZ Std.
End Flange Dimensions	JIS B2220
Wall Thickness	ASME B16.34 Class 300

Unit:mm

Nominal Size	20UMAJ/20UMAJM							
	$1/2 \times 1\frac{1}{2}$	$3/4 \times 1\frac{1}{2}$	1×2	$1\frac{1}{2} \times 2\frac{1}{2}$	2×3	3×4	4×6	6×8
L	15×40	20×40	25×50	40×65	50×80	80×100	100×150	150×200
H (open)	173	173	181	192	270	289	386	434
H	199	213	232	283	353	470	560	753
D	100	100	100	140	180	225	250	350
P	Rc $1/2$	Rc $1/2$	Rc $1/2$	Rc $1/2$	Rc $1/2$	Rc $1/2$	Rc $3/4$	Rc $3/4$

\*The nominal sizes are indicated by [the valve nominal sizes] and [flange nominal sizes].

**CLASS 150**

**FULL JACKETED GLOBE VALVE**

Pressure-Temperature Rating:  
ASME B 16.34

150UPAJ

150UPAJM

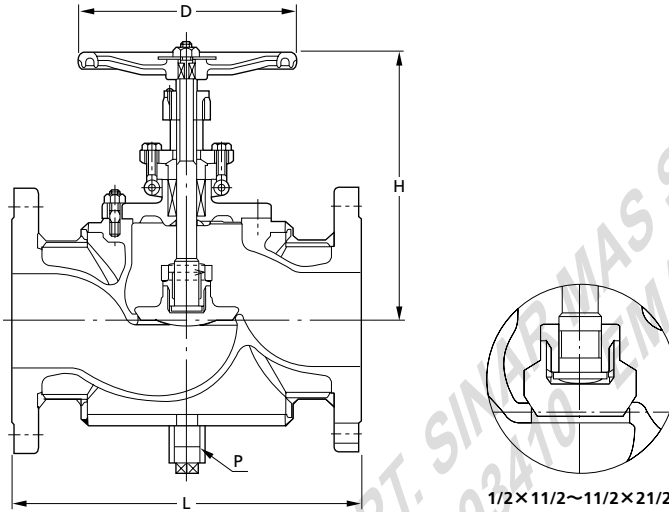

**Materials**

Parts	150UPAJ	150UPAJM
Body	CF8	CF8M
Bonnet	CF8	CF8M
Stem	304	316
Disc	1/2 to 2	304
	3 & 4	CF8
Lock nut	1/2 to 1 1/2	304
	2 to 4	CF8
Gland	304	316
Gland flange	CF8	
Gland packing	Refer to Page 10	
Gasket	Refer to Page 10	
Yoke bush	Ductile Ni-resist	
Handwheel	FCD400	Ductile iron
Gland bolt/nut	B8/8	
Gland bolt pin	SUS403	403
Bonnet bolt/nut	B8/8	
Name plate	A1050P	
Jacket*	Carbon Steel+Steel	

\*The material may be changed depending on the service temperature.  
Note: Body seats and/or disc seats can be optionally hard-faced.

Items	
Face-to-Face Dimensions	KITZ Std.
End Flange Dimensions	JIS B2220, ASME B16.5
Wall Thickness	ASME B16.34 Class 150

Nominal Size		1/2 x 1 1/2	3/4 x 1 1/2	1 x 2	1 1/2 x 2 1/2	2 x 3	3 x 4	4 x 6
		15 x 40	20 x 40	25 x 50	40 x 65	50 x 80	80 x 100	100 x 150
L	in.	6.00	6.00	7.50	8.40	9.50	11.50	14.00
	mm	152	152	190	213	241	292	356
H (open)	in.	7.3	7.3	7.4	9.3	9.3	11.5	12.8
	mm	186	186	187	236	237	293	326
D	in.	3.9	3.9	3.9	6.3	6.3	7.9	8.9
	mm	100	100	100	160	160	200	225
P		Rc 1/2	Rc 1/2	Rc 1/2	Rc 1/2	Rc 1/2	Rc 1/2	Rc 3/4

\*The nominal sizes are indicated by [the valve nominal sizes] and [flange nominal sizes].

**CLASS 300**

**FULL JACKETED GLOBE VALVE**

Pressure-Temperature Rating:  
ASME B 16.34

300UPAJ

300UPAJM

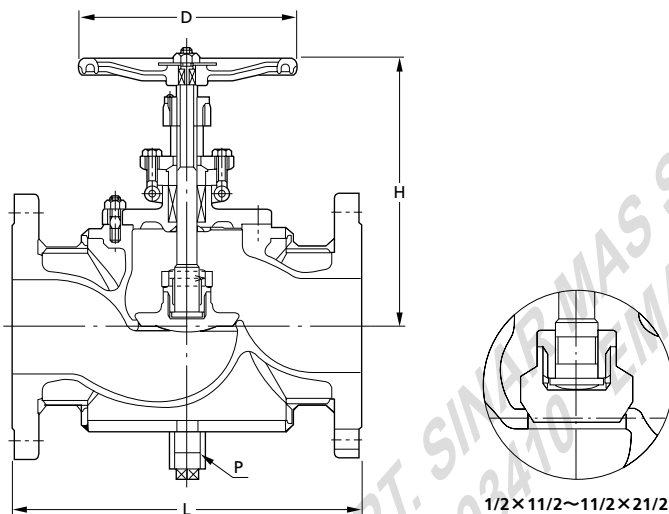

**Materials**

Parts	300UPAJ	300UPAJM
Body	CF8	CF8M
Bonnet	CF8	CF8M
Stem	304	316
Disc	1/2 to 2 3 & 4 CF8	316 CF8M
Lock nut	1/2 to 1 1/2 2 to 4 CF8	316 CF8M
Gland	SCS13A	CF8
Gland flange	CF8	
Gland packing	Refer to Page 10	
Gasket	Refer to Page 10	
Yoke bush	Ductile Ni-resist	
Handwheel	FCD400	Ductile iron
Gland bolt/nut	B8/8	
Gland bolt pin	SUS403	403
Bonnet bolt/nut	B8/8	
Name plate	Aluminum	
Jacket*	Carbon Steel+Steel	

\*The material may be changed depending on the service temperature.  
Note: Body seats and/or disc seats can be optionally hard-faced.

Items	
Face-to-Face Dimensions	KITZ Std.
End Flange Dimensions	JIS B2220, ASME B16.5
Wall Thickness	ASME B16.34 Class 300

Nominal Size		1/2 x 1 1/2	3/4 x 1 1/2	1 x 2	1 1/2 x 2 1/2	2 x 3	3 x 4	4 x 6
		15 x 40	20 x 40	25 x 50	40 x 65	50 x 80	80 x 100	100 x 150
L	in.	6.50	6.50	8.00	9.00	10.50	12.50	14.00
	mm	165	165	203	229	267	318	356
H (open)	in.	7.3	7.3	7.4	9.3	11.4	13.5	11.7
	mm	186	186	187	236	289	343	298
D	in.	3.9	3.9	3.9	6.3	7.1	9.8	11.8
	mm	100	100	100	160	180	250	300
P		Rc 1/2	Rc 1/2	Rc 1/2	Rc 1/2	Rc 1/2	Rc 1/2	Rc 3/4

\*The nominal sizes are indicated by [the valve nominal sizes] and [flange nominal sizes].

10K

FULL JACKETED GLOBE VALVE

Pressure-Temperature Rating: JIS B2220

10UPAJ

10UPAJM

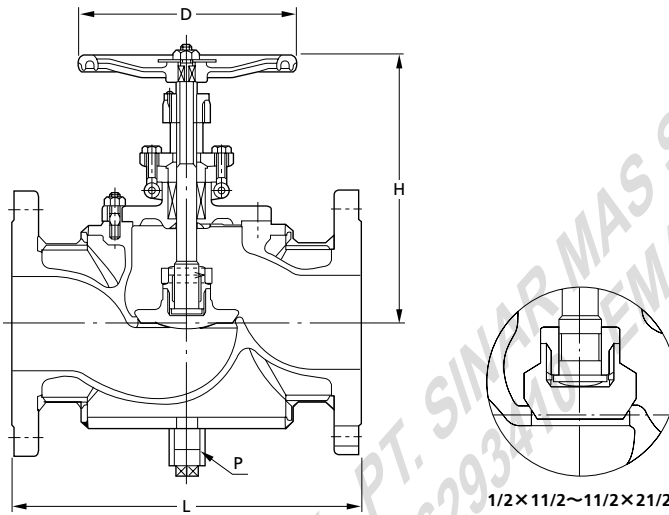

Materials

Parts	10UPAJ	10UPAJM	
Body	SCS13A	SCS14A	
Bonnet	SCS13A	SCS14A	
Stem	SUS304	SUS316	
Disc	1/2 to 2	SUS304	SUS316
	3 & 4	SCS13A	SCS14A
Lock nut	1/2 to 1 1/2	SUS304	SUS316
	2 to 4	SCS13A	SCS14A
Gland	SUS304	SUS316	
Gland flange	SCS13A		
Gland packing	Refer to Page 10		
Gasket	Refer to Page 10		
Yoke bush	Ductile Ni-resist		
Handwheel	FCD400		
Gland bolt/nut	SUS304/304		
Gland bolt pin	SUS403		
Bonnet bolt/nut	SUS304/304		
Name plate	A1050P		
Jacket*	STPG370+SS400		

\*The material may be changed depending on the service temperature.  
Note: Body seats and/or disc seats can be optionally hard-faced.

Items	
Face-to-Face Dimensions	KITZ Std.
End Flange Dimensions	JIS B2220
Wall Thickness	ASME B16.34 Class 150

Unit:mm

Nominal Size	1/2 x 1 1/2	3/4 x 1 1/2	1 x 2	1 1/2 x 2 1/2	2 x 3	3 x 4	4 x 6
L	156	156	190	214	239	280	349
H (open)	186	186	187	236	237	293	326
D	100	100	100	160	160	200	225
P	Rc1/2	Rc1/2	Rc1/2	Rc1/2	Rc1/2	Rc1/2	Rc3/4

\*The nominal sizes are indicated by [the valve nominal sizes] and [flange nominal sizes].

20K

FULL JACKETED GLOBE VALVE

Pressure-Temperature Rating: JIS B2220

20UPAJ

20UPAJM

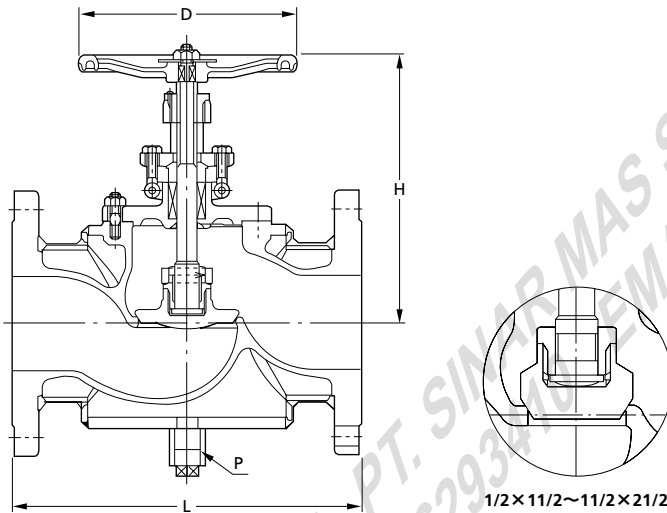

Materials

Parts	20UPAJ	20UPAJM
Body	SCS13A	SCS14A
Bonnet	SCS13A	SCS14A
Stem	SUS304	SUS316
Disc	1/2 to 2	SUS304
	3 & 4	SCS13A
Lock nut	1/2 to 1 1/2	SUS304
	2 to 4	SCS13A
Gland	SUS304	SUS316
Gland flange	SCS13A	
Gland packing	Refer to Page 10	
Gasket	Refer to Page 10	
Yoke bush	Ductile Ni-resist	
Handwheel	FCD400	
Gland bolt/nut	SUS304/304	
Gland bolt pin	SUS403	
Bonnet bolt/nut	SUS304/304	
Name plate	A1050P	
Jacket*	STPG370+SS400	

\*The material may be changed depending on the service temperature.  
Note: Body seats and/or disc seats can be optionally hard-faced.

Items	
Face-to-Face Dimensions	KITZ Std.
End Flange Dimensions	JIS B2220
Wall Thickness	ASME B16.34 Class 300

Unit:mm

Nominal Size	1/2 x 1 1/2	3/4 x 1 1/2	1 x 2	1 1/2 x 2 1/2	2 x 3	3 x 4	4 x 6
L	15 x 40	20 x 40	25 x 50	40 x 65	50 x 80	80 x 100	100 x 150
H (open)	160	160	194	218	254	302	339
H	186	186	187	236	289	343	398
D	100	100	100	160	180	250	300
P	Rc 1/2	Rc 1/2	Rc 1/2	Rc 1/2	Rc 1/2	Rc 1/2	Rc 3/4

\*The nominal sizes are indicated by [the valve nominal sizes] and [flange nominal sizes].

**CLASS 150**

**FULL JACKETED SWING CHECK VALVE**

Pressure-Temperature Rating:  
ASME B 16.34

150UOAJ

150UOAJM

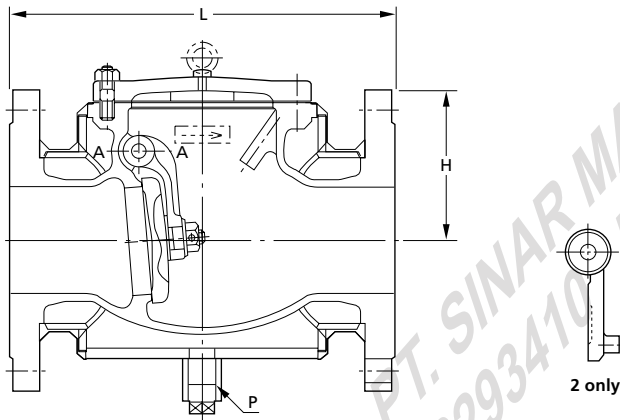

**Materials**

Parts	150UOAJ	150UOAJM
Body	CF8	CF8M
Cover	CF8	CF8M
Disc	CF8	CF8M
Gasket	Refer to Page 10	
Hinge pin	304	316
Plug	304	316
Cover bolt/nut	B8/8	
Split pin	SUS316L	316L
Jacket*	STPG370+S5400	Carbon Steel+Steel

\*The material may be changed depending on the service temperature.  
Note: Body seats and/or disc seats can be optionally hard-faced.

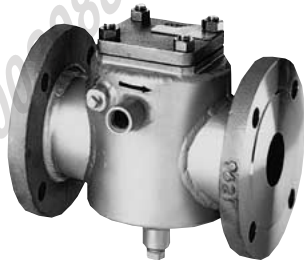

Items	
Face-to-Face Dimensions	KITZ Std.
End Flange Dimensions	ASME B16.5
Wall Thickness	ASME B16.34 Class 150

Nominal Size	2×3		3×4		4×6		6×8	
	50×80		80×100		100×150		150×200	
L	in.	9.50	11.50	14.00	16.00			
	mm	241	292	356	406			
H (open)	in.	4.8	5.9	6.7	8.4			
	mm	122	149	171	214			
P		Rc1/2	Rc1/2	Rc3/4	Rc3/4			

\*The nominal sizes are indicated by [the valve nominal sizes] and [flange nominal sizes].

**CLASS 300**

**FULL JACKETED CHECK VALVE**

Pressure-Temperature Rating:  
ASME B 16.34

300UOAJ

300UOAJM

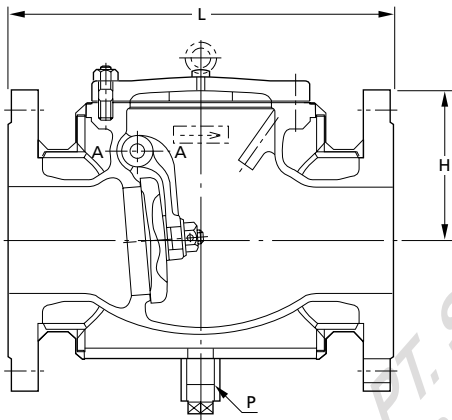

PROVIDED BY: PT. SINAR MAS SAKTI  
 TEL: (62 21) 6092388 FAX: (62 21) 6293410 EMAIL: sales@smsakti.com

**Materials**

Parts	300UOAJ	300UOAJM
Body	CF8	CF8M
Cover	CF8	CF8M
Disc	CF8	CF8M
Gasket	Refer to Page 10	
Hinge pin	304	316
Plug	304	316
Cover bolt/nut	B8/8	
Split pin	SUS316L	316L
Jacket*	STPG370+S5400	Carbon Steel+Steel

\*The material may be changed depending on the service temperature.  
 Note: Body seats and/or disc seats can be optionally hard-faced.

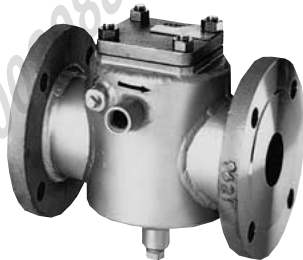

Items	
Face-to-Face Dimensions	KITZ Std.
End Flange Dimensions	ASME B16.5
Wall Thickness	ASME B16.34 Class 300

Nominal Size	2×3		3×4		4×6		6×8	
	50×80		80×100		100×150		150×200	
L	in.	10.50	13.00	15.71	17.50			
	mm	267	330	400	444			
H (open)	in.	5.7	7.1	7.9	10			
	mm	146	180	200	255			
P		Rc1/2	Rc1/2	Rc3/4	Rc3/4			

\*The nominal sizes are indicated by [the valve nominal sizes] and [flange nominal sizes].

10K

FULL JACKETED SWING CHECK VALVE

Pressure-Temperature Rating:  
JIS B2220

10UOAJ

10UOAJM

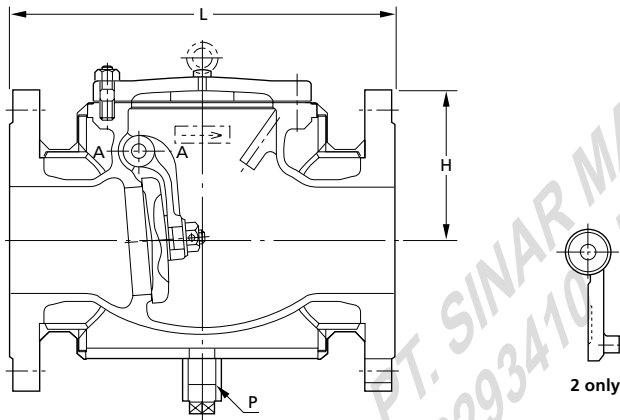

Materials

Parts	10UOAJ	10UOAJM
Body	SCS13A	SCS14A
Cover	SCS13A	SCS14A
Disc	SCS13A	SCS14A
Gasket	Refer to Page 10	
Hinge pin	SUS304	SUS316
Plug	SUS304	SUS316
Cover bolt/nut	SUS304/304	
Split pin	SUS316L	
Jacket*	STPG370+SS400	

\*The material may be changed depending on the service temperature.  
Note: Body seats and/or disc seats can be optionally hard-faced.

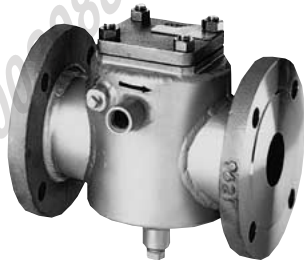

Items	
Face-to-Face Dimensions	KITZ Std.
End Flange Dimensions	JIS B2220
Wall Thickness	ASME B16.34 Class 150

Unit:mm

Nominal Size	2×3	3×4	4×6	6×8
	50×80	80×100	100×150	150×200
L	239	280	349	393
H	122	149	171	214
P	Rc1/2	Rc1/2	Rc3/4	Rc3/4

\*The nominal sizes are indicated by [the valve nominal sizes] and [flange nominal sizes].

20K

FULL JACKETED CHECK VALVE

Pressure-Temperature Rating:  
JIS B2220

20UOAJ

20UOAJM

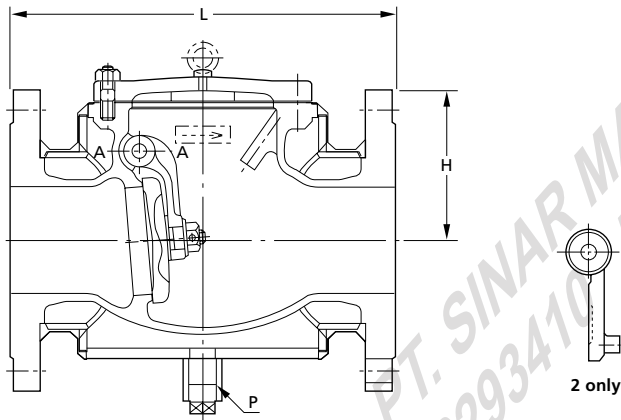

Materials

Parts	20UOAJ	20UOAJM
Body	SCS13A	SCS14A
Cover	SCS13A	SCS14A
Disc	SCS13A	SCS14A
Gasket	Refer to Page 10	
Hinge pin	SUS304	SUS316
Plug	SUS304	SUS316
Cover bolt/nut	SUS304/304	
Split pin	SUS316L	
Jacket*	STPG370+SS400	

\*The material may be changed depending on the service temperature.  
Note: Body seats and/or disc seats can be optionally hard-faced.



Items	
Face-to-Face Dimensions	KITZ Std.
End Flange Dimensions	JIS B2220
Wall Thickness	ASME B16.34

Unit:mm

Nominal Size	2×3	3×4	4×6	6×8
	50×80	80×100	100×150	150×200
L	254	314	383	421
H	146	180	200	255
P	Rc1/2	Rc1/2	Rc3/4	Rc3/4

\*The nominal sizes are indicated by [the valve nominal sizes] and [flange nominal sizes].

**CLASS 150**

**FULL JACKETED LIFT CHECK VALVE**

Pressure-Temperature Rating:  
ASME B 16.34

150UNAJ

150UNAJM

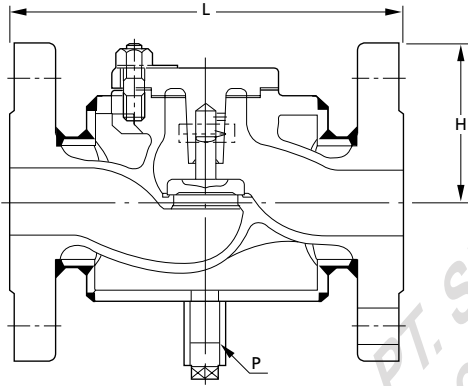

**Materials**

Parts	150UNAJ	150UNAJM
Body	CF8	CF8M
Cover	CF8	CF8M
Disc	304	316
Gasket	Refer to Page 10	
Cover bolt/nut	B8/8	
Jacket*	STPG370+SS400	Carbon Steel+Steel

\*The material may be changed depending on the service temperature.  
Note: Body seats and/or disc seats can be optionally hard-faced.

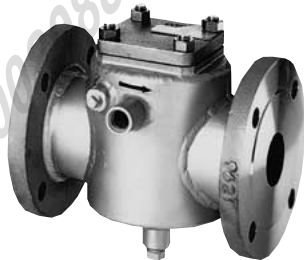

Items	
Face-to-Face Dimensions	KITZ Std.
End Flange Dimensions	ASME B16.5
Wall Thickness	ASME B16.34 Class 150

Nominal Size	1/2×1 1/2		3/4×1 1/2		1×2		1 1/2×2 1/2	
	15×40		20×40		25×50		40×65	
<b>L</b>	in.	6.00	6.00	7.50	8.40			
	mm	152	152	190	213			
<b>H (open)</b>	in.	2.9	2.9	2.9	3.5			
	mm	73	73	73	90			
<b>P</b>		Rc1/2	Rc1/2	Rc1/2	Rc1/2			

\*The nominal sizes are indicated by [the valve nominal sizes] and [flange nominal sizes].

**CLASS 300**

**FULL JACKETED CHECK VALVE**

Pressure-Temperature Rating:  
ASME B 16.34

300UNAJ

300UNAJM

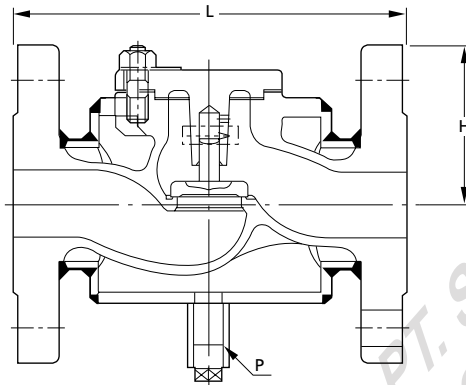

**Materials**

Parts	300UNAJ	300UNAJM
Body	CF8	CF8M
Cover	CF8	CF8M
Disc	304	316
Gasket	Refer to Page 10	
Cover bolt/nut	B8/8	
Jacket*	STPG370+S5400	Carbon Steel+Steel

\*The material may be changed depending on the service temperature.  
Note: Body seats and/or disc seats can be optionally hard-faced.

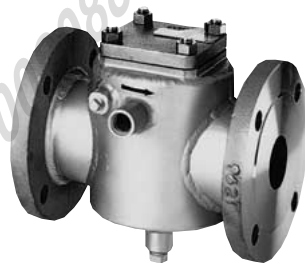

Items	
Face-to-Face Dimensions	KITZ Std.
End Flange Dimensions	ASME B16.5
Wall Thickness	ASME B16.34 Class 300

Nominal Size	1/2×1 1/2		3/4×1 1/2		1×2		1 1/2×2 1/2	
	15×40		20×40		25×50		40×65	
<b>L</b>	in.	6.50	6.50	6.50	8.00	8.00	9.00	9.00
	mm	165	165	165	203	203	229	229
<b>H (open)</b>	in.	2.9	2.9	2.9	2.9	2.9	3.5	3.5
	mm	73	73	73	73	73	90	90
<b>P</b>		Rc1/2	Rc1/2	Rc1/2	Rc1/2	Rc1/2	Rc1/2	Rc1/2

\*The nominal sizes are indicated by [the valve nominal sizes] and [flange nominal sizes].

PROVIDED BY: PT. SINAR MAS SAKTI  
 TEL: (62 21) 6000288 FAX: (62 21) 6293410 EMAIL: sales@smsakti.com

10K

FULL JACKETED LIFT CHECK VALVE

Pressure-Temperature Rating: JIS B2220

10UNAJ

10UNAJM

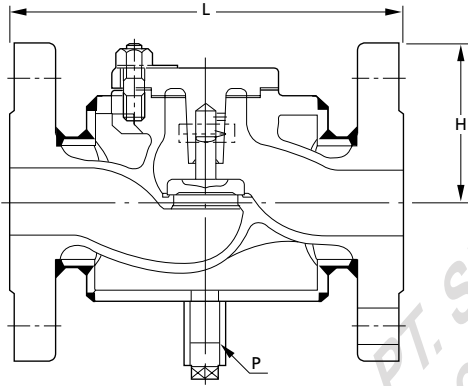

Materials

Parts	10UNAJ	10UNAJM
Body	SCS13A	SCS14A
Cover	SCS13A	SCS14A
Disc	SUS304	SUS316
Gasket	Refer to Page 10	
Cover bolt/nut	SUS304/304	
Jacket*	STPG370+SS400	

\*The material may be changed depending on the service temperature.  
Note: Body seats and/or disc seats can be optionally hard-faced.



Items	
Face-to-Face Dimensions	KITZ Std.
End Flange Dimensions	JIS B2220
Wall Thickness	ASME B16.34 Class 150

Nominal Size	Unit:mm			
	1/2×1 1/2	3/4×1 1/2	1×2	1 1/2×2 1/2
L	15×40	20×40	25×50	40×65
H	156	156	190	214
P	73	73	73	90
	Rc1/2	Rc1/2	Rc1/2	Rc1/2

\*The nominal sizes are indicated by [the valve nominal sizes] and [flange nominal sizes].

20K

FULL JACKETED CHECK VALVE

Pressure-Temperature Rating: JIS B2220

20UNAJ

20UNAJM

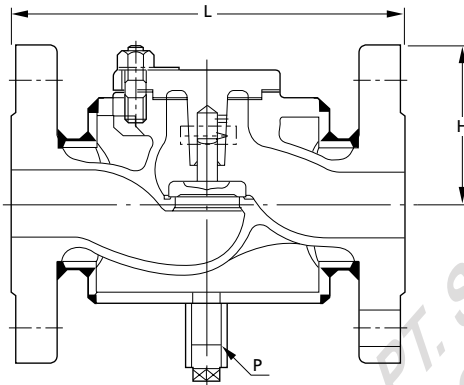

Materials

Parts	20UNAJ	20UNAJM
Body	SCS13A	SCS14A
Cover	SCS13A	SCS14A
Disc	SUS304	SUS316
Gasket	Refer to Page 10	
Cover bolt/nut	SUS304/304	
Jacket*	STPG370+SS400	

\*The material may be changed depending on the service temperature.  
Note: Body seats and/or disc seats can be optionally hard-faced.



Items	
Face-to-Face Dimensions	KITZ Std.
End Flange Dimensions	JIS B2220
Wall Thickness	ASME B16.34 Class 300

Nominal Size	Unit:mm			
	1/2×1 1/2	3/4×1 1/2	1×2	1 1/2×2 1/2
L	15×40	20×40	25×50	40×65
H	160	160	194	218
P	73	73	73	90
	Rc1/2	Rc1/2	Rc1/2	Rc1/2

\*The nominal sizes are indicated by [the valve nominal sizes] and [flange nominal sizes].

**Pressure-Temperature Ratings <For reference>  
Standard Class Valves, Flanged and Butt Weld End.**

ASME Material Standard-to ASME B 16.34 2004

Service Temperature		Working Pressures by Class, psig														
		Class 150			Class 300			Class 600			Class 900			Class 1500		
°F	°C	CF8	CF8M CF3M**	SDPV***	CF8	CF8M CF3M**	SDPV***	CF8	CF8M CF3M**	SDPV***	CF8	CF8M CF3M**	SDPV***	CF8	CF8M CF3M**	SDPV***
-20 to 100	-29 to 38	275	275	290	720	720	750	1,440	1,440	1,500	2,160	2,160	2,250	3,600	3,600	3,750
200	93	230	235	260	600	620	745	1,200	1,240	1,490	1,800	1,860	2,230	3,000	3,095	3,720
300	149	205	215	230	540	560	665	1,075	1,120	1,335	1,615	1,680	2,000	2,690	2,795	3,335
400	204	190	195	200	495	515	615	995	1,025	1,230	1,490	1,540	1,845	2,485	2,570	3,070
500	260	170	170	170	465	480	580	930	955	1,160	1,395	1,435	1,740	2,330	2,390	2,905
600	316	140	140	140	440	450	555	885	900	1,115	1,325	1,355	1,670	2,210	2,255	2,785
650	343	125	125		430	440		865	885		1,295	1,325		2,160	2,210	
700	371	110	110		420	435		845	870		1,265	1,305		2,110	2,170	
750	399	95	95		415	425		825	855		1,240	1,280		2,065	2,135	
800	427	80	80		405	420		810	845		1,215	1,265		2,030	2,110	
850	454	65	65		395	420		790	835		1,190	1,255		1,980	2,090	
900	482	50	50		390	415		780	830		1,165	1,245		1,945	2,075	
950	510	35	35		380	385		765	775		1,145	1,160		1,910	1,930	
1000	538	20	20		355	365		710	725		1,065	1,090		1,770	1,820	
1050	566	20*	20*		325	360		650	720		975	1,080		1,630	1,800	
1100	593	20*	20*		255	305		515	610		770	915		1,285	1,525	
1150	621	20*	20*		205	235		410	475		615	710		1,030	1,185	
1200	649	20*	20*		165	185		330	370		495	555		825	925	
1250	677	20*	20*		135	145		265	295		400	440		670	735	
1300	704	20*	20*		115	115		225	235		340	350		565	585	
1350	732	20*	20*		95	95		185	190		280	290		465	480	
1400	760	20*	20*		75	75		150	150		225	225		380	380	
1450	788	20*	20*		60	60		115	115		175	175		290	290	
1500	816	15*	15*		40	40		85	85		125	125		205	205	

\* Applied to welding end valves only. Flanged end valve ratings terminate at 538°C (1000 F).  
 \*\* Permissible, but not recommended for prolonged usage above 454°C (850 F).  
 \*\*\* SDPV is the trademark registered for KITZ Super Duplex Stainless Steel, which is comparable to 25Cr-7Ni-4Mo-N castings.

**Pressure-Temperature Ratings for Series B (KITZ Standard)**

Temperature	MPa		
	W	G1	G2
	120°C below	150°C below	180°C below
5K	0.7	0.5	—
10K	1.4	1.1	1.0
20K	2.0	1.2	1.0

W: Static water without pressure variation  
 G1,G2: Steam, air, non-inflammable gas and oil (lubricant and machining oil)  
 Note: Actual pressure-temperature rating in service depends on the materials of gland packing and gasket chosen for valves.

**Valve Closure Test Pressures**

Series	B (KITZ Std.)		
	Hydrostatic		Air
	Shell	Seat	Seat
5K	1.05	0.77	0.59
10K	2.10	1.54	
20K	3.00	—	—

Note: Test pressure for check valves to JIS B2003

## Care for Handling Valves

### 1. Before mounting valves:

Before mounting valves, be sure that adequate valves have been prepared to exactly meet the service conditions including the maximum design pressures and temperatures. Foreign objects such as sands or scales may be left in the pipes, and care should be taken to remove all of them by filters or strainers to protect valves seat surfaces during subsequent valve commissioning.

### 2. Mounting valves:

On mounting valves, clean the inside of pipes again so that no welding spatters, chips, scales or sands are left. For installation of flanged end valves, flange bolts should be tightened alternately in a star pattern. Where extraordinary external forces such as piping stress may be applied to the flanges of valves being mounted, provide valve supports or any other adequate protective measures. For socket welding works, refer to Page 31 of this catalog.

### 3. Retightening valves glands:

When leakage is detected from the gland area while the valve is being in service, the gland should be immediately retightened. Tighten the gland slowly and gradually until the leakage stops, while rotating the valve handwheel. In case the valve operating torque has been found considerably increased after these procedures, it is recommended to replace all packing rings at the time of valve maintenance.

### 4. Replacing packing rings:

It is recommended to replace packing rings during valve maintenance operation, but never while the valve is being pressurized in service, except the line pressure is reduced to the atmospheric level. KITZ stainless steel valves (Series A, AJ, C and D) are provided with the backseats or bonnet bushes. If leakage from the gland area cannot be stopped by retightening the gland, operate the valve to its full open position and add a few packing rings or replace packing rings utilizing sealing function of these backseats.

Sealing function of backseats is sometimes disturbed due to rust or other foreign objects trapped inside. It should be carefully checked before adding or replacing packing rings that backseats function properly. When the valve is highly pressurized, it sometimes causes danger to replace all of packing rings. In this case, adding a few new rings or replacing a few rings on top of the packing chamber is recommended as a first aid solution.

For replacement of packing rings, first remove the gland bolts and then packing rings. Clean the packing chamber and the valve stem. After checking that all sliding parts are in good condition, securely install new packing rings. Press new packing rings lightly a few times with the gland and then evenly tighten the gland.

### KITZ Protect Warranty

All KITZ stainless and high alloy steel valves are guaranteed for 12 months after placement in service, but not exceeding 18 months after shipment from the factories of KITZ Corporation, provided that the valves are properly handled according to the relevant KITZ operation manual.

*Memo*

PROVIDED BY: PT. SINAR MAS SAKTI  
TEL: (62 21) 6008088 FAX: (62 21) 6293410 EMAIL: sales@smsakti.com

 **CAUTION**

Pressure-temperature ratings and other performance data published in this catalog have been developed from our design calculation, in-house testing, field reports provided by our customers and/or published official standards or specifications. They are good only to cover typical applications as a general guideline to users of KITZ products introduced in this catalog.

For any specific application, users are kindly requested to contact KITZ Corporation for technical advice, or to carry out their own study and evaluation for proving suitability of these products to such an application. Failure to follow this request could result in property damage and/or personal injury, for which we shall not be liable.

While this catalog has been compiled with the utmost care, we assume no responsibility for errors, impropriety or inadequacy. Any information provided in this catalog is subject to from-time-to-time change without notice for error rectification, product discontinuation, design modification, new product introduction or any other cause that KITZ Corporation considers necessary. This edition cancels all previous issues.

ISO 9001 certified since 1989

**KITZ**  
KITZ CORPORATION

1-10-1, Nakase, Mihama-ku, Chiba 261-8577, Japan  
International Sales Dept. Phone : 81-43-299-1730, 1732 and 1733  
Fax : 81-43-299-0121

— Distributed by —